

NET December 2016

SET-B

Part A

Q1. Find out the missing pattern.

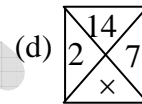
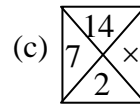
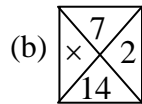
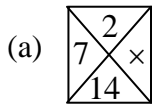
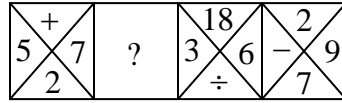

Q2. Seeds when soaked in water gain about 20% by weight and 10% by volume. By what factor does the density increase?

- (a) 1.20 (b) 1.10 (c) 1.11 (d) 1.09

Q3. Retarding frictional force, f , on a moving ball, is proportional to its velocity, V . Two identical balls roll down identical slopes (A & B) from different heights. Compare the retarding forces and the velocities of the balls at the bases of the slopes.

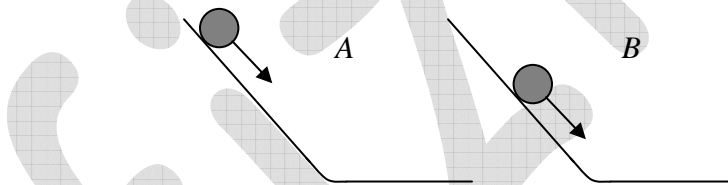

- (a) $f_A > f_B; V_A > V_B$ (b) $f_A > f_B; V_B > V_A$
 (c) $f_B > f_A; V_B > V_A$ (d) $f_B > f_A; V_A > V_B$

Q4. Two cockroaches of the same species have the same thickness but different lengths and widths. Their ability to survive in oxygen deficient environments will be compromised if

- (a) their thickness increases, and the rest of the size remains the same.
 (b) their thickness remains unchanged, but their length increases.
 (c) their thickness remains unchanged, but their width decreases.
 (d) their thickness decreases, but the rest of the size remains unchanged.

Head office

fiziks, H.No. 40 D, G.F, Jia Sarai,
 Near IIT, Hauz Khas, New Delhi-16
 Phone: 011-26865455/+91-9871145498

Branch office

Anand Institute of Mathematics,
 28-B/6, Jia Sarai, Near IIT
 Hauz Khas, New Delhi-16

- Q5. The bar chart shows number of seats won by four political parties in a state legislative assembly.

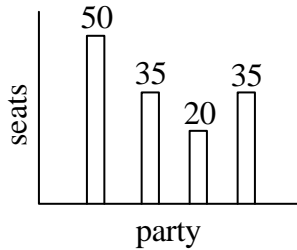

Which of the following pie-charts correctly depicts this information?

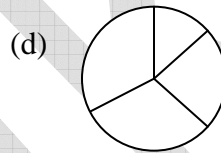
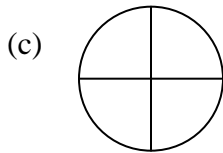
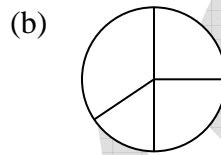
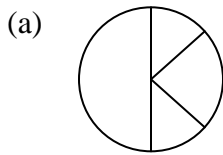

- Q6. The random errors associated with the measurement of P and Q are 10% and 2% respectively, What is the percentage random error in $\frac{P}{Q}$?
- (a) 12.0 (b) 9.8 (c) 8.0 (d) 10.2
- Q7. In how many distinguishable ways can the letters of the word CHANCE be arranged?
- (a) 120 (b) 720 (c) 360 (d) 240
- Q8. Which of the following graphs correctly shows the speed and the corresponding distance covered by an object moving along a straight line?

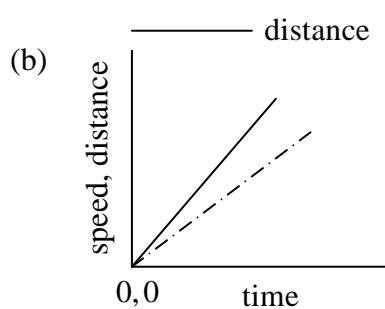
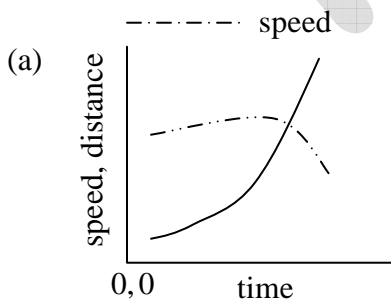

Head office

fiziks, H.No. 40 D, G.F, Jia Sarai,
Near IIT, Hauz Khas, New Delhi-16
Phone: 011-26865455/+91-9871145498

Branch office

Anand Institute of Mathematics,
28-B/6, Jia Sarai, Near IIT
Hauz Khas, New Delhi-16

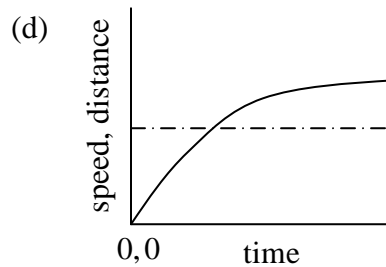
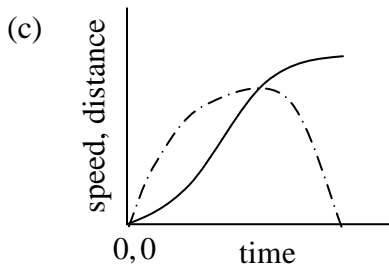

Q9. A normal TV screen has a width to height ratio of 4 : 3, while a high definition TV screen has a ratio of 16 : 9. What is the approximate ratio of their diagonals, if the heights of the two types of screens are the same?

- (a) 5 : 9 (b) 5 : 18 (c) 5 : 15 (d) 5 : 6

Q10. Comparing numerical values, which of the following is different from the rest?

- (a) The ratio of the circumference of a circle to its diameter.
 (b) The sum of the three angles of a plane triangle expressed in radians.
 (c) $\frac{22}{7}$.
 (d) The net volume of a hemisphere of unit radius, and a cone of unit radius and unit height

Q11. A river is 4.1 km wide. A bridge built across it has $\frac{1}{7}$ of its length on one-bank and $\frac{1}{8}$ of its length on the other bank. What is the total length of the bridge?

- (a) 5.1 km (b) 4.9 km (c) 5.6 km (d) 5.4 km

Q12. $OA, OB,$ and OC are radii of the quarter circle shown in the figure. AB is also equal to the radius.

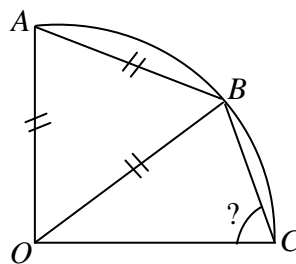

what is angle OCB ?

- (a) 60° (b) 75° (c) 55° (d) 65°

Head office

fiziks, H.No. 40 D, G.F, Jia Sarai,
 Near IIT, Hauz Khas, New Delhi-16
 Phone: 011-26865455/+91-9871145498

Branch office

Anand Institute of Mathematics,
 28-B/6, Jia Sarai, Near IIT
 Hauz Khas, New Delhi-16

Q13. Intravenous (IV) fluid has to be administered to a child of 12 kg with dehydration, at a dose of 20 mg of fluid per kg of body weight, in 1 hour. What should be the drip rate (in drops/min of IV fluid)? ($1\text{ mg} = 20$ drops)

- (a) 7 (b) 80 (c) 120 (d) 4

Q14. A hall with a high roof is supported by an array of identical columns such that, to a person lying on the floor and looking at the ceiling, the columns appear parallel to each other. Which of the following designs conforms to this?

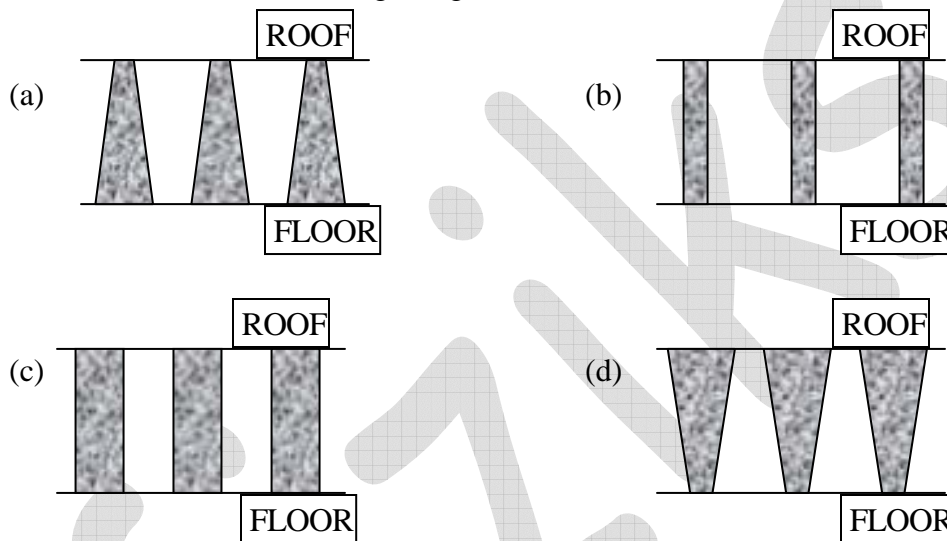

Q15. The sum of digits of a two-digit number is 9. If the fraction formed by taking 9 less than the number as numerator and 9 more than the number as denominator is $\frac{3}{4}$, what is the number?

- (a) 36 (b) 63 (c) 45 (d) 54

Head office

fiziks, H.No. 40 D, G.F, Jia Sarai,
Near IIT, Hauz Khas, New Delhi-16
Phone: 011-26865455/+91-9871145498

Branch office

Anand Institute of Mathematics,
28-B/6, Jia Sarai, Near IIT
Hauz Khas, New Delhi-16

- Q16. The distance between X and Y is 1000 km . A person flies from X at 8 A.M. local time and reaches Y at 10 A.M. local time. He flies back after a halt of 4 hours at Y and reaches X at 4 P.M. local time on the same day. What is his average speed for the duration he is in the air?
- (a) 500 km/hour
(b) 250 km/hour
(c) 750 km/hour
(d) cannot be calculated with the given information
- Q17. If a person travels $x\%$ faster than normal, he reaches y minutes earlier than normal. What is his normal time of travel?
- (a) $\left(\frac{100}{x} + 1\right)y$ minutes
(b) $\left(\frac{x}{100} + 1\right)y$ minutes
(c) $\left(\frac{y}{100} + 1\right)x$ minutes
(d) $\left(\frac{100}{y} + 1\right)x$ minutes
- Q18. A and B walk up an escalator one step at a time, while the escalator itself moves up at a constant speed. A walks twice as fast as B . A reaches the top in 40 steps and B in 30 steps. How many steps of the escalator can be seen when it is not moving?
- (a) 30 (b) 40 (c) 50 (d) 60
- Q19. Two iron spheres of radii 12cm and 1cm are melted and fused. Two new spheres are made without any loss of iron. Their possible radii could be
- (a) 9 and 4cm (b) 9 and 10cm
(c) 8 and 5cm (d) 2 and 11cm
- Q20. A man buys alcohol at Rs $75/cL$, adds water, and sells it at Rs. $75/cL$ making a profit of 50%. What is the ratio of alcohol to water?
- (a) 2:1 (b) 1:2 (c) 3:2 (d) 2:3

Head office

fiziks, H.No. 40 D, G.F, Jia Sarai,
Near IIT, Hauz Khas, New Delhi-16
Phone: 011-26865455/+91-9871145498

Branch office

Anand Institute of Mathematics,
28-B/6, Jia Sarai, Near IIT
Hauz Khas, New Delhi-16

Part B

Q21. A ball of mass m is dropped from a tall building with zero initial velocity. In addition to gravity, the ball experiences a damping force of the form $-\gamma v$, where v is its instantaneous velocity and γ is a constant. Given the values $m=10\text{kg}$, $\gamma=10\text{kg/s}$, and $g \approx 10\text{m/s}^2$ the distance travelled (in metres) in time t in seconds, is

- (a) $10(t+1-e^{-t})$ (b) $10(t-1+e^{-t})$
 (c) $5t^2 - (1-e^t)$ (d) $5t^2$

Q22. The matrix $M = \begin{pmatrix} 1 & 3 & 2 \\ 3 & -1 & 0 \\ 0 & 0 & 1 \end{pmatrix}$ satisfies the equation

- (a) $M^3 - M^2 - 10M + 12I = 0$ (b) $M^3 + M^2 - 12M + 10I = 0$
 (c) $M^3 - M^2 - 10M + 10I = 0$ (d) $M^3 + M^2 - 10M + 10I = 0$

Q23. The Laplace transform of

$$f(t) = \begin{cases} \frac{t}{T}, & 0 < t < T \\ 1 & t > T \end{cases}$$

is

- (a) $\frac{-(1-e^{-sT})}{s^2T}$ (b) $\frac{(1-e^{-sT})}{s^2T}$ (c) $\frac{(1+e^{-sT})}{s^2T}$ (d) $\frac{(1-e^{sT})}{s^2T}$

Q24. A relativistic particle moves with a constant velocity v with respect to the laboratory frame. In time τ , measured in the rest frame of the particle, the distance that it travels in the laboratory frame is

- (a) $v\tau$ (b) $\frac{c\tau}{\sqrt{1-\frac{v^2}{c^2}}}$ (c) $v\tau\sqrt{1-\frac{v^2}{c^2}}$ (d) $\frac{v\tau}{\sqrt{1-\frac{v^2}{c^2}}}$

Head office

fiziks, H.No. 40 D, G.F, Jia Sarai,
Near IIT, Hauz Khas, New Delhi-16
Phone: 011-26865455/+91-9871145498

Branch office

Anand Institute of Mathematics,
28-B/6, Jia Sarai, Near IIT
Hauz Khas, New Delhi-16

Q25. A particle in two dimensions is in a potential $V(x, y) = x + 2y$. Which of the following (apart from the total energy of the particle) is also a constant of motion?

- (a) $p_y - 2p_x$ (b) $p_x - 2p_y$
(c) $p_x + 2p_y$ (d) $p_y + 2p_x$

Q26. The dynamics of a particle governed by the Lagrangian

$$L = \frac{1}{2}m\dot{x}^2 - \frac{1}{2}kx^2 - kx\dot{x}t$$
 describes

- (a) an undamped simple harmonic oscillator
(b) a damped harmonic oscillator with a time varying damping factor
(c) an undamped harmonic oscillator with a time dependent frequency
(d) a free particle

Q27. The parabolic coordinates (ξ, η) are related to the Cartesian coordinates (x, y) by

$x = \xi\eta$ and $y = \frac{1}{2}(\xi^2 - \eta^2)$. The Lagrangian of a two-dimensional simple harmonic oscillator of mass m and angular frequency ω is

- (a) $\frac{1}{2}m\left[\dot{\xi}^2 + \dot{\eta}^2 - \omega^2(\xi^2 + \eta^2)\right]$
(b) $\frac{1}{2}m(\xi^2 + \eta^2)\left[(\dot{\xi}^2 + \dot{\eta}^2) - \frac{1}{4}\omega^2(\xi^2 + \eta^2)\right]$
(c) $\frac{1}{2}m(\xi^2 + \eta^2)\left[\dot{\xi}^2 + \dot{\eta}^2 - \frac{1}{2}\omega^2\xi\eta\right]$
(d) $\frac{1}{2}m(\xi^2 + \eta^2)\left[\dot{\xi}^2 + \dot{\eta}^2 - \frac{1}{4}\omega^2\right]$

Q28. Consider two radioactive atoms, each of which has a decay rate of 1 per year. The probability that at least one of them decays in the first two years is

- (a) $\frac{1}{4}$ (b) $\frac{3}{4}$ (c) $1 - e^{-4}$ (d) $(1 - e^{-2})^2$

Head office

fiziks, H.No. 40 D, G.F, Jia Sarai,
Near IIT, Hauz Khas, New Delhi-16
Phone: 011-26865455/+91-9871145498

Branch office

Anand Institute of Mathematics,
28-B/6, Jia Sarai, Near IIT
Hauz Khas, New Delhi-16

Q29. The Fourier transform $\int_{-\infty}^{\infty} dx f(x) e^{ikx}$ of the function $f(x) = \frac{1}{x^2 + 2}$ is

- (a) $\sqrt{2}\pi e^{-\sqrt{2}|k|}$ (b) $\sqrt{2}\pi e^{-\sqrt{2}k}$ (c) $\frac{\pi}{\sqrt{2}} e^{-\sqrt{2}k}$ (d) $\frac{\pi}{\sqrt{2}} e^{-\sqrt{2}|k|}$

Q30. A screen has two slits, each of width w with their centres at a distance $2w$ apart. It is illuminated by a monochromatic plane wave travelling along the x -axis.

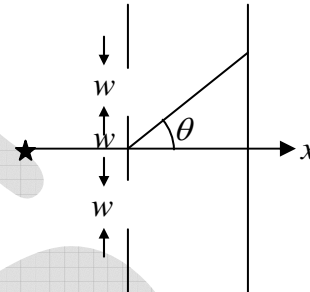

The intensity of the interference pattern, measured on a distant screen, at an angle

$$\theta = \frac{n\lambda}{w}$$

to the x -axis is

- (a) zero for $n = 1, 2, 3, \dots$
 (b) maximum for $n = 1, 2, 3, \dots$
 (c) maximum for $n = \frac{1}{2}, \frac{3}{2}, \frac{5}{2}, \dots$
 (d) zero for $n = 0$ only

Q31. The electric field of an electromagnetic wave is

$$\vec{E}(z, t) = E_0 \cos(kz + \omega t) \hat{i} + 2E_0 \sin(kz + \omega t) \hat{j}$$

where ω and k are positive constants. This represents

- (a) a linearly polarised wave travelling in the positive z -direction
 (b) a circularly polarised wave travelling in the negative z -direction
 (c) an elliptically polarised wave travelling in the negative z -direction
 (d) an unpolarised wave travelling in the positive z -direction

Q32. Consider the two lowest normalized energy eigenfunctions $\psi_0(x)$ and $\psi_1(x)$ of a one dimensional system. They satisfy $\psi_0(x) = \psi_0^*(x)$ and $\psi_1(x) = \alpha \frac{d\psi_0}{dx}$, where α is a real constant. The expectation value of the momentum operator in the state ψ_1 is

- (a) $-\frac{\hbar}{\alpha^2}$ (b) 0 (c) $\frac{\hbar}{\alpha^2}$ (d) $\frac{2\hbar}{\alpha^2}$

Head office

fiziks, H.No. 40 D, G.F, Jia Sarai,
 Near IIT, Hauz Khas, New Delhi-16
 Phone: 011-26865455/+91-9871145498

Branch office

Anand Institute of Mathematics,
 28-B/6, Jia Sarai, Near IIT
 Hauz Khas, New Delhi-16

Q33. Consider the operator $a = x + \frac{d}{dx}$ acting on smooth functions of x . The commutator

$[\alpha, \cos x]$ is

- (a) $-\sin x$ (b) $\cos x$ (c) $-\cos x$ (d) 0

Q34. Let $a = \frac{1}{\sqrt{2}}(x + ip)$ and $a^\dagger = \frac{1}{\sqrt{2}}(x - ip)$ be the lowering and raising operators of a simple harmonic oscillator in units where the mass, angular frequency and \hbar have been set to unity. If $|0\rangle$ is the ground state of the oscillator and λ is a complex constant, the expectation value of $\langle \psi | x | \psi \rangle$ in the state $|\psi\rangle = \exp(\lambda a^\dagger - \lambda^* a)|0\rangle$, is

- (a) $|\lambda|$ (b) $\sqrt{|\lambda|^2 + \frac{1}{|\lambda|^2}}$ (c) $\frac{1}{\sqrt{2}i}(\lambda - \lambda^*)$ (d) $\frac{1}{\sqrt{2}}(\lambda + \lambda^*)$

Q35. Consider the operator $\vec{\pi} = \vec{p} - q\vec{A}$, where \vec{p} is the momentum operator, $\vec{A} = (A_x, A_y, A_z)$ is the vector potential and q denotes the electric charge. If $\vec{B} = (B_x, B_y, B_z)$ denotes the magnetic field, the z -component of the vector operator $\vec{\pi} \times \vec{\pi}$ is

- (a) $iq\hbar B_z + q(A_x p_y - A_y p_x)$ (b) $-iq\hbar B_z - q(A_x p_y - A_y p_x)$
(c) $-iq\hbar B_z$ (d) $iq\hbar B_z$

Q36. A conducting circular disc of radius r and resistivity ρ rotates with an angular velocity ω in a magnetic field B perpendicular to it. A voltmeter is connected as shown in the figure below. Assuming its internal resistance to be infinite, the reading on the voltmeter

- (a) depends on ω, B, r and ρ
(b) depends on ω, B and r but not on ρ
(c) is zero because the flux through the loop is not changing
(d) is zero because a current the flows in the direction of B

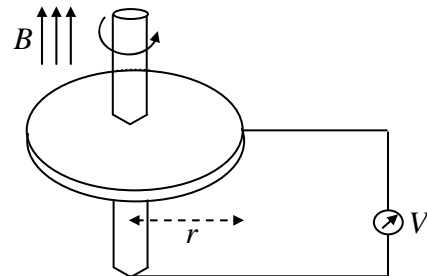

Head office

fiziks, H.No. 40 D, G.F, Jia Sarai,
Near IIT, Hauz Khas, New Delhi-16
Phone: 011-26865455/+91-9871145498

Branch office

Anand Institute of Mathematics,
28-B/6, Jia Sarai, Near IIT
Hauz Khas, New Delhi-16

Q37. The charge per unit length of a circular wire of radius a in the xy -plane, with its centre at the origin, is $\lambda = \lambda_0 \cos \theta$, where λ_0 is a constant and the angle θ is measured from the positive x -axis. The electric field at the centre of the circle is

(a) $\vec{E} = -\frac{\lambda_0}{4\epsilon_0} \hat{i}$

(b) $\vec{E} = \frac{\lambda_0}{4\epsilon_0} \hat{i}$

(c) $\vec{E} = -\frac{\lambda_0}{4\epsilon_0} \hat{j}$

(d) $\vec{E} = \frac{\lambda_0}{4\pi\epsilon_0} \hat{k}$

Q38. The partition function of a two-level system governed by the Hamiltonian

$$H = \begin{bmatrix} \gamma & -\delta \\ -\delta & -\gamma \end{bmatrix}$$

is

(a) $2 \sinh(\beta\sqrt{\gamma^2 + \delta^2})$

(b) $2 \cosh(\beta\sqrt{\gamma^2 + \delta^2})$

(c) $\frac{1}{2} \left[\cosh(\beta\sqrt{\gamma^2 + \delta^2}) + \sinh(\beta\sqrt{\gamma^2 + \delta^2}) \right]$

(d) $\frac{1}{2} \left[\cosh(\beta\sqrt{\gamma^2 + \delta^2}) - \sinh(\beta\sqrt{\gamma^2 + \delta^2}) \right]$

Q39. A silica particle of radius $0.1 \mu\text{m}$ is put in a container of water at $T = 300 \text{ K}$. The densities of silica and water are 2000 kg/m^3 and 1000 kg/m^3 , respectively. Due to thermal fluctuations, the particle is not always at the bottom of the container. The average height of the particle above the base of the container is approximately

(a) 10^{-3} m

(b) $3 \times 10^{-4} \text{ m}$

(c) 10^{-4} m

(d) $5 \times 10^{-5} \text{ m}$

Head office

fiziks, H.No. 40 D, G.F, Jia Sarai,
Near IIT, Hauz Khas, New Delhi-16
Phone: 011-26865455/+91-9871145498

Branch office

Anand Institute of Mathematics,
28-B/6, Jia Sarai, Near IIT
Hauz Khas, New Delhi-16

Q40. Which of the following circuits implements the Boolean function

$$F(A, B, C) = \sum(1, 2, 4, 6)?$$

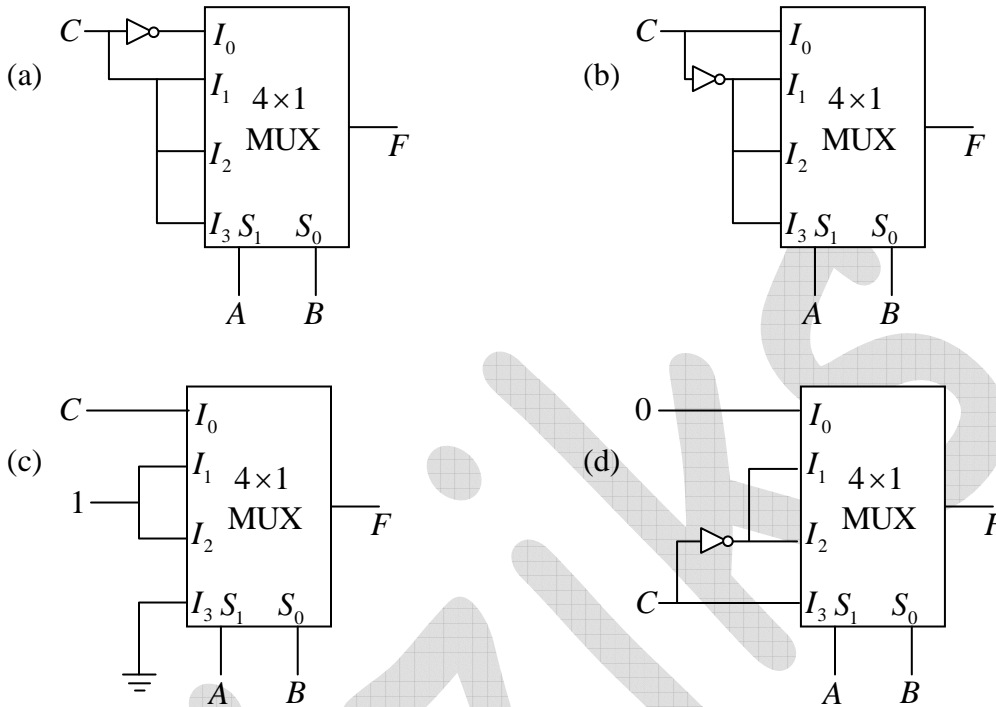

Q41. A pair of parallel glass plates separated by a distance d is illuminated by white light as shown in the figure below. Also shown is the graph of the intensity of the reflected light I as a function of the wavelength λ recorded by a spectrometer.

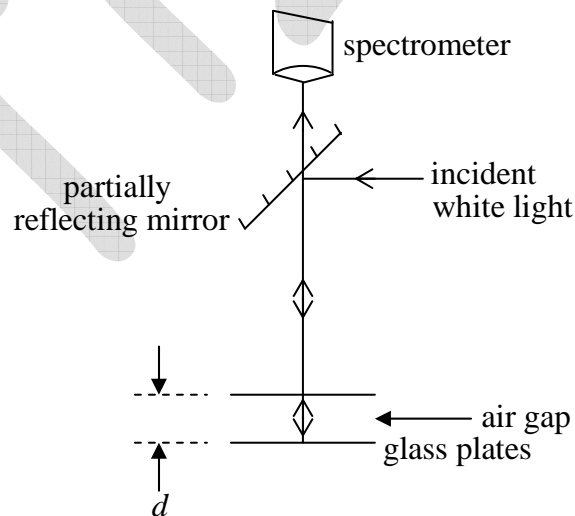

Head office

fiziks, H.No. 40 D, G.F, Jia Sarai,
Near IIT, Hauz Khas, New Delhi-16
Phone: 011-26865455/+91-9871145498

Branch office

Anand Institute of Mathematics,
28-B/6, Jia Sarai, Near IIT
Hauz Khas, New Delhi-16

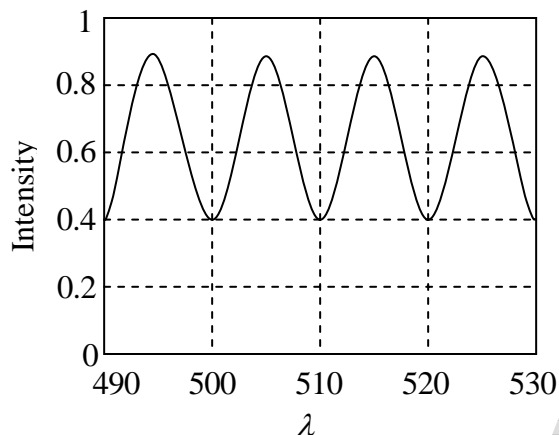

Assuming that the interference takes place only between light reflected by the bottom surface of the top plate and the top surface of bottom plate, the distance d is closest to

- (a) $12 \mu\text{m}$ (b) $24 \mu\text{m}$ (c) $60 \mu\text{m}$ (d) $120 \mu\text{m}$

Q42. The $I-V$ characteristics of a device can be expressed as $I = I_s \left[\exp\left(\frac{aV}{T}\right) - 1 \right]$, where T is the temperature and a and I_s are constants independent of T and V . Which one of the following plots is correct for a fixed applied voltage V ?

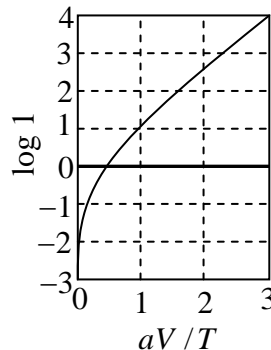
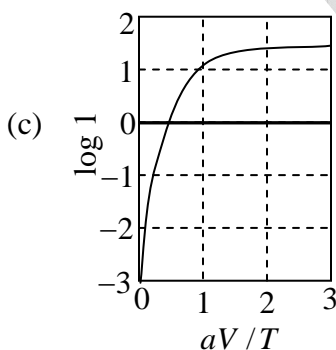
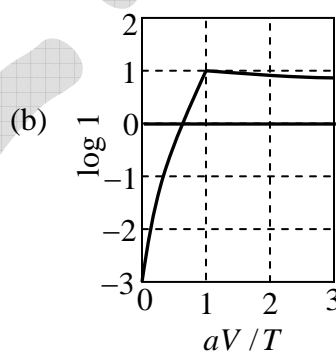
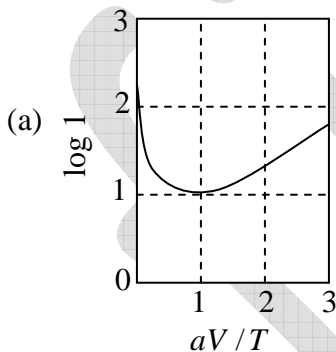

Head office

fiziks, H.No. 40 D, G.F, Jia Sarai,
Near IIT, Hauz Khas, New Delhi-16
Phone: 011-26865455/+91-9871145498

Branch office

Anand Institute of Mathematics,
28-B/6, Jia Sarai, Near IIT
Hauz Khas, New Delhi-16

- Q43. The active medium in a blue LED (light emitting diode) is a $Ga_xIn_{1-x}N$ alloy. The band gaps of GaN and InN are $3.5 eV$ and $1.5 eV$ respectively. If the band gap of $Ga_xIn_{1-x}N$ varies approximately linearly with x , the value of x required for the emission of blue light of wavelength $400 nm$ is (take $hc \approx 1200 eV \cdot nm$)
- (a) 0.95 (b) 0.75 (c) 0.50 (d) 0.33
- Q44. Consider a gas of N classical particles in a two-dimensional square box of side L . If the total energy of the gas is E , the entropy (apart from an additive constant) is
- (a) $Nk_B \ln\left(\frac{L^2 E}{N}\right)$ (b) $Nk_B \ln\left(\frac{LE}{N}\right)$
(c) $2Nk_B \ln\left(\frac{L\sqrt{E}}{N}\right)$ (d) $L^2 k_B \ln\left(\frac{E}{N}\right)$
- Q45. Consider a continuous time random walk. If a step has taken place at time $t = 0$, the probability that the next step takes place between t and $t + dt$ is given by $bt dt$, where b is a constant. What is the average time between successive steps?
- (a) $\sqrt{\frac{2\pi}{b}}$ (b) $\sqrt{\frac{\pi}{b}}$ (c) $\frac{1}{2}\sqrt{\frac{\pi}{b}}$ (d) $\sqrt{\frac{\pi}{2b}}$

Head office

fiziks, H.No. 40 D, G.F, Jia Sarai,
Near IIT, Hauz Khas, New Delhi-16
Phone: 011-26865455/+91-9871145498

Branch office

Anand Institute of Mathematics,
28-B/6, Jia Sarai, Near IIT
Hauz Khas, New Delhi-16

PART C

Q46. Given the values $\sin 45^\circ = 0.7071$, $\sin 50^\circ = 0.7660$, $\sin 55^\circ = 0.8192$ and $\sin 60^\circ = 0.8660$, the approximate value of $\sin 52^\circ$, computed by Newton's forward difference method, is

- (a) 0.804 (b) 0.776 (c) 0.788 (d) 0.798

Q47. Let $f(x, t)$ be a solution of the heat equation $\frac{\partial f}{\partial t} = D \frac{\partial^2 f}{\partial x^2}$ in one dimension. The initial condition at $t = 0$ is $f(x, 0) = e^{-x^2}$ for $-\infty < x < \infty$. Then for all $t > 0$, $f(x, t)$ is given by

[Useful integral: $\int_{-\infty}^{\infty} dx e^{-\alpha x^2} = \sqrt{\frac{\pi}{\alpha}}$]

- (a) $\frac{1}{\sqrt{1+Dt}} e^{-\frac{x^2}{1+Dt}}$ (b) $\frac{1}{\sqrt{1+2Dt}} e^{-\frac{x^2}{1+2Dt}}$
 (c) $\frac{1}{\sqrt{1+4Dt}} e^{-\frac{x^2}{1+4Dt}}$ (d) $e^{-\frac{x^2}{1+Dt}}$

Q48. After a perfectly elastic collision of two identical balls, one of which was initially at rest, the velocities of both the balls are non zero. The angle θ between the final, velocities (in the lab frame) is

- (a) $\theta = \frac{\pi}{2}$ (b) $\theta = \pi$
 (c) $0 < \theta \leq \frac{\pi}{2}$ (d) $\frac{\pi}{2} < \theta \leq \pi$

Q49. Consider circular orbits in a central force potential $V(r) = -\frac{k}{r^n}$, where $k > 0$ and $0 < n < 2$. If the time period of a circular orbit of radius R is T_1 and that of radius $2R$ is

T_2 , then $\frac{T_2}{T_1}$

- (a) $2^{\frac{n}{2}}$ (b) $2^{\frac{2}{3n}}$ (c) $2^{\frac{n+1}{2}}$ (d) 2^n

Head office

fiziks, H.No. 40 D, G.F, Jia Sarai,
Near IIT, Hauz Khas, New Delhi-16
Phone: 011-26865455/+91-9871145498

Branch office

Anand Institute of Mathematics,
28-B/6, Jia Sarai, Near IIT
Hauz Khas, New Delhi-16

Q50. Consider a radioactive nucleus that is travelling at a speed $\frac{c}{2}$ with respect to the lab frame. It emits γ -rays of frequency ν_0 in its rest frame. There is a stationary detector, (which is not on the path of the nucleus) in the lab. If a γ -ray photon is emitted when the nucleus is closest to the detector, its observed frequency at the detector is

- (a) $\frac{\sqrt{3}}{2}\nu_0$ (b) $\frac{1}{\sqrt{3}}\nu_0$ (c) $\frac{1}{\sqrt{2}}\nu_0$ (d) $\sqrt{\frac{2}{3}}\nu_0$

Q51. Suppose that free charges are present in a material of dielectric constant $\epsilon=10$ and resistivity $\rho = 10^{11} \Omega - m$. Using Ohm's law and the equation of continuity for charge, the time required for the charge density inside the material to decay by $\frac{1}{e}$ is closest to

- (a) $10^{-6} S$ (b) $10^6 S$ (c) $10^{12} S$ (d) $10 S$

Q52. A particle with charge $-q$ moves with a uniform angular velocity ω in a circular orbit of radius a in the xy -plane, around a fixed charge $+q$, which is at the centre of the orbit at $(0,0,0)$. Let the intensity of radiation at the point $(0,0,R)$ be I_1 and at $(2R,0,0)$ be I_2

The ratio $\frac{I_2}{I_1}$ for $R \gg a$, is

- (a) 4 (b) $\frac{1}{4}$ (c) $\frac{1}{8}$ (d) 8

Q53. A parallel plate capacitor is formed by two circular conducting plates of radius a separated by a distance d , where $d \ll a$. It is being slowly charged by a current that is nearly constant. At an instant when the current is I , the magnetic induction between the plates at a distance $\frac{a}{2}$ from the centre of the plate, is

- (a) $\frac{\mu_0 I}{\pi a}$ (b) $\frac{\mu_0 I}{2\pi a}$ (c) $\frac{\mu_0 I}{a}$ (d) $\frac{\mu_0 I}{4\pi a}$

Head office

fiziks, H.No. 40 D, G.F, Jia Sarai,
Near IIT, Hauz Khas, New Delhi-16
Phone: 011-26865455/+91-9871145498

Branch office

Anand Institute of Mathematics,
28-B/6, Jia Sarai, Near IIT
Hauz Khas, New Delhi-16

Q54. Two uniformly charged insulating solid spheres A and B , both of radius a , carry total charges $+Q$ and $-Q$, respectively. The spheres are placed touching each other as shown in the figure.

If the potential at the centre of the sphere A is V_A and that at the centre of B is V_B then the difference $V_A - V_B$ is

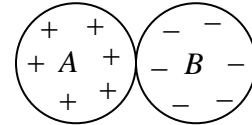

- (a) $\frac{Q}{4\pi\epsilon_0 a}$ (b) $\frac{-Q}{2\pi\epsilon_0 a}$ (c) $\frac{Q}{2\pi\epsilon_0 a}$ (d) $\frac{-Q}{4\pi\epsilon_0 a}$

Q55. A stable asymptotic solution of the equation $x_{n+1} = 1 + \frac{3}{1+x_n}$ is $x=2$. If we take

$x_n = 2 + \epsilon_n$ and $x_{n+1} = 2 + \epsilon_{n+1}$, where ϵ_n and ϵ_{n+1} are both small, the ratio $\frac{\epsilon_{n+1}}{\epsilon_n}$ is approximately

- (a) $-\frac{1}{2}$ (b) $-\frac{1}{4}$ (c) $-\frac{1}{3}$ (d) $-\frac{2}{3}$

Q56. The 2×2 identity matrix I and the Pauli matrices $\sigma^x, \sigma^y, \sigma^z$ do not form a group under matrix multiplication. The minimum number of 2×2 matrices, which includes these four matrices, and form a group (under matrix multiplication) is

- (a) 20 (b) 8 (c) 12 (d) 16

Q57. The dynamics of a free relativistic particle of mass m is governed by the Dirac Hamiltonian $H = c\vec{\alpha} \cdot \vec{p} + \beta mc^2$, where \vec{p} is the momentum operator and $\vec{\alpha} = (\alpha_x, \alpha_y, \alpha_z)$ and β are four 4×4 Dirac matrices. The acceleration operator can be expressed as

- (a) $\frac{2ic}{\hbar}(c\vec{p} - \vec{\alpha}H)$ (b) $2ic^2\vec{\alpha}\beta$
 (c) $\frac{ic}{\hbar}H\vec{\alpha}$ (d) $-\frac{2ic}{\hbar}(c\vec{p} + \vec{\alpha}H)$

Head office

fiziks, H.No. 40 D, G.F, Jia Sarai,
Near IIT, Hauz Khas, New Delhi-16
Phone: 011-26865455/+91-9871145498

Branch office

Anand Institute of Mathematics,
28-B/6, Jia Sarai, Near IIT
Hauz Khas, New Delhi-16

Q58. A particle of charge q in one dimension is in a simple harmonic potential with angular frequency ω . It is subjected to a time-dependent electric field $E(t) = Ae^{-\left(\frac{t}{\tau}\right)^2}$, where A and τ are positive constants and $\omega\tau \gg 1$. If in the distant past $t \rightarrow -\infty$ the particle was in its ground state, the probability that it will be in the first excited state as $t \rightarrow +\infty$ is proportional to

- (a) $e^{-\frac{1}{2}(\omega\tau)^2}$ (b) $e^{\frac{1}{2}(\omega\tau)^2}$ (c) 0 (d) $\frac{1}{(\omega\tau)^2}$

Q59. Consider a random walk on an infinite two-dimensional triangular lattice, a part of which is shown in the figure below.

If the probabilities of moving to any of the nearest neighbour sites are equal, what is the probability that the walker returns to the starting position at the end of exactly three steps?

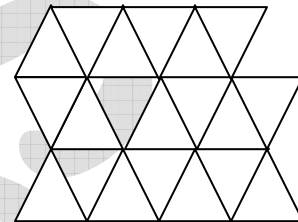

- (a) $\frac{1}{36}$ (b) $\frac{1}{216}$ (c) $\frac{1}{18}$ (d) $\frac{1}{12}$

Q60. An atom has a non-degenerate ground-state and a doubly-degenerate excited state. The energy difference between the two states is ε . The specific heat at very low temperatures ($\beta\varepsilon \gg 1$) is given by

- (a) $k_B(\beta\varepsilon)$ (b) $k_B e^{-\beta\varepsilon}$
(c) $2k_B(\beta\varepsilon)^2 e^{-\beta\varepsilon}$ (d) k_B

Q61. The electrons in graphene can be thought of as a two-dimensional gas with a linear energy-momentum relation $E = |\vec{p}|v$, where $\vec{p} = (p_x, p_y)$ and v is a constant. If ρ is the number of electrons per unit area, the energy per unit area is proportional to

- (a) $\rho^{3/2}$ (b) ρ (c) $\rho^{1/3}$ (d) ρ^2

Head office

fiziks, H.No. 40 D, G.F, Jia Sarai,
Near IIT, Hauz Khas, New Delhi-16
Phone: 011-26865455/+91-9871145498

Branch office

Anand Institute of Mathematics,
28-B/6, Jia Sarai, Near IIT
Hauz Khas, New Delhi-16

Q62. In the circuit below, the input voltage V_i is $2V$, $V_{cc} = 16V$, $R_2 = 2k\Omega$ and $R_L = 10k\Omega$

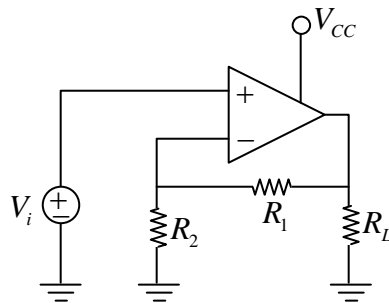

The value of R_1 required to deliver $10mW$ of power across R_L is

- (a) $12k\Omega$ (b) $4k\Omega$ (c) $8k\Omega$ (d) $14k\Omega$

Q63. Two sinusoidal signals are sent to an analog multiplier of scale factor $1V^{-1}$ followed by a low pass filter (LPF).

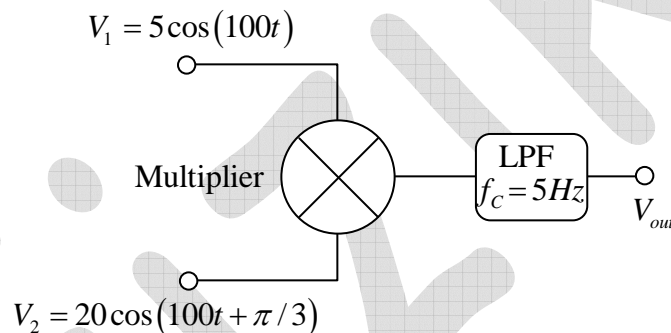

If the roll-off frequency of the LPF is $f_c = 5Hz$, the output voltage V_{out} is

- (a) $5V$ (b) $25V$ (c) $100V$ (d) $50V$

Q64. The resistance of a sample is measured as a function of temperature, and the data are shown below.

$T(^{\circ}C)$	2	4	6	8
$R(\Omega)$	90	105	110	115

The slope of R vs T graph, using a linear least-squares fit to the data, will be

- (a) $\frac{6\Omega}{^{\circ}C}$ (b) $\frac{4\Omega}{^{\circ}C}$ (c) $\frac{2\Omega}{^{\circ}C}$ (d) $\frac{8\Omega}{^{\circ}C}$

Head office

fiziks, H.No. 40 D, G.F, Jia Sarai,
Near IIT, Hauz Khas, New Delhi-16
Phone: 011-26865455/+91-9871145498

Branch office

Anand Institute of Mathematics,
28-B/6, Jia Sarai, Near IIT
Hauz Khas, New Delhi-16

Q65. A particle is scattered by a central potential $V(r) = V_0 r e^{-\mu r}$, where V_0 and μ are positive constants. If the momentum transfer \vec{q} is such that $q = |\vec{q}| \gg \mu$, the scattering cross-section in the Born approximation, as $q \rightarrow \infty$, depends on q as

[You may use $\int x^n e^{ax} dx = \frac{d^n}{da^n} \int e^{ax} dx$]

- (a) q^{-8} (b) q^{-2} (c) q^2 (d) q^6

Q66. A particle in one dimension is in a potential $V(x) = A\delta(x-a)$. Its wavefunction $\psi(x)$ is continuous everywhere. The discontinuity in $\frac{d\psi}{dx}$ at $x=a$ is

- (a) $\frac{2m}{\hbar^2} A\psi(a)$ (b) $A(\psi(a) - \psi(-a))$
 (c) $\frac{\hbar^2}{2m} A$ (d) 0

Q67. Consider a hexagonal lattice with basis vectors as shown in the figure below.

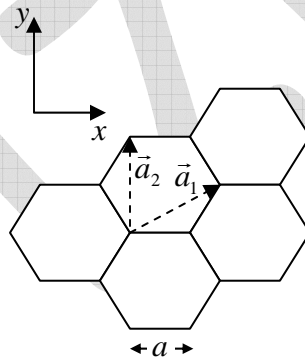

If the lattice spacing is $a=1$, the reciprocal lattice vectors are

- (a) $\left(\frac{4\pi}{3}, 0\right), \left(-\frac{2\pi}{3}, \frac{2\pi}{\sqrt{3}}\right)$ (b) $\left(\frac{4\pi}{3}, 0\right), \left(\frac{2\pi}{3}, \frac{2\pi}{\sqrt{3}}\right)$
 (c) $\left(0, \frac{4\pi}{3}\right), \left(\pi, \frac{2\pi}{\sqrt{3}}\right)$ (d) $\left(\frac{2\pi}{3}, \frac{2\pi}{\sqrt{3}}\right), \left(-2\pi, \frac{2\pi}{\sqrt{3}}\right)$

Head office

fiziks, H.No. 40 D, G.F, Jia Sarai,
 Near IIT, Hauz Khas, New Delhi-16
 Phone: 011-26865455/+91-9871145498

Branch office

Anand Institute of Mathematics,
 28-B/6, Jia Sarai, Near IIT
 Hauz Khas, New Delhi-16

- Q68. In the $L-S$ coupling scheme, the terms arising from two non-equivalent p -electrons are
- (a) ${}^3S, {}^1P, {}^3P, {}^1D, {}^3D$ (b) ${}^1S, {}^3S, {}^1P, {}^1D$
 (c) ${}^1S, {}^3S, {}^3P, {}^3D$ (d) ${}^1S, {}^3S, {}^1P, {}^3P, {}^1D, {}^3D$
- Q69. The total spin of a hydrogen atom is due to the contribution of the spins of the electron and the proton. In the high temperature limit, the ratio of the number of atoms in the spin-1 state to the number in the spin-0 state is
- (a) 2 (b) 3 (c) $\frac{1}{2}$ (d) $\frac{1}{3}$
- Q70. A two level system in a thermal (black body) environment can decay from the excited state by both spontaneous and thermally stimulated emission. At room temperature (300 K), the frequency below which thermal emission dominates over spontaneous emission is nearest to
- (a) 10^{13} Hz (b) 10^8 Hz (c) 10^5 Hz (d) 10^{11} Hz
- Q71. What should be the minimum energy of a photon for it to split an α -particle at rest into a tritium and a proton?
 (The masses of ${}^4_2\text{He}$, ${}^3_1\text{H}$ and ${}^1_1\text{H}$ are 4.0026 amu , 3.0161 amu and 1.0073 amu respectively, and $1\text{ amu} \approx 938\text{ MeV}$)
- (a) 32.2 MeV (b) 3 MeV (c) 19.3 MeV (d) 931.5 MeV
- Q72. Which of the following reaction(s) is/are allowed by the conservation laws?
- (i) $\pi^+ + n \rightarrow \Lambda^0 + K^+$
 (ii) $\pi^- + p \rightarrow \Lambda^0 + K^0$
- (a) both (i) and (ii) (b) only (i)
 (c) only (ii) (d) neither (i) nor (ii)

Head office

fiziks, H.No. 40 D, G.F, Jia Sarai,
 Near IIT, Hauz Khas, New Delhi-16
 Phone: 011-26865455/+91-9871145498

Branch office

Anand Institute of Mathematics,
 28-B/6, Jia Sarai, Near IIT
 Hauz Khas, New Delhi-16

Q73. A particle, which is a composite state of three quarks u, d and s , has electric charge, spin and strangeness respectively, equal to

- (a) $1, \frac{1}{2}, -1$ (b) $0, 0, -1$ (c) $0, \frac{1}{2}, -1$ (d) $-1, -\frac{1}{2}, +1$

Q74. Consider a one-dimensional chain of atoms with lattice constant a . The energy of an electron with wave-vector k is $\epsilon(k) = \mu - \gamma \cos(ka)$, where μ and γ are constants. If an electric field E is applied in the positive x -direction, the time dependent velocity of an electron is

(In the following B is the constant)

- (a) Proportional to $\cos\left(B - \frac{eE}{\hbar}at\right)$ (b) proportional to E
 (c) independent of E (d) proportional to $\sin\left(B - \frac{eE}{\hbar}at\right)$

Q75. A thin rectangular conducting plate of length a and width b is placed in the xy -plane in two different orientations as shown in the figures below. In both cases a magnetic field B is applied in the z -direction and a current flows in the x direction due to the applied voltage V .

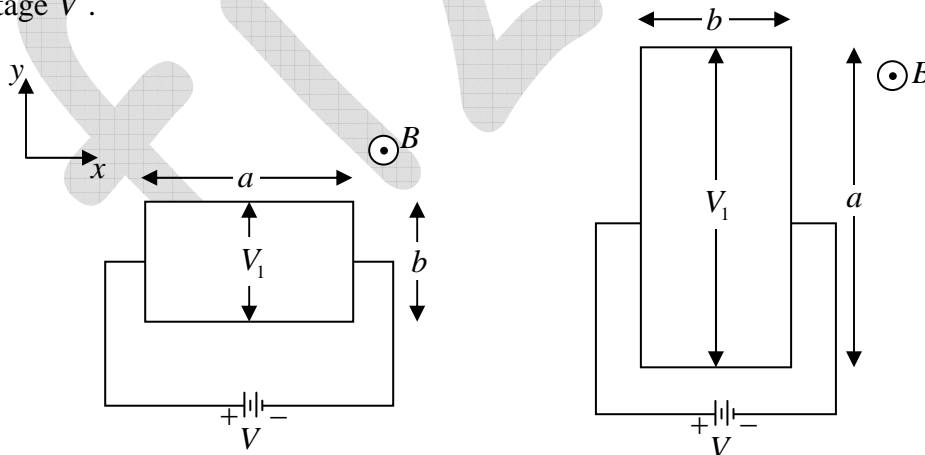

If the Hall voltage across the y -direction in the two cases satisfy $V_2 = 2V_1$ the ratio $a : b$ must be

- (a) $1 : 2$ (b) $1 : \sqrt{2}$ (c) $2 : 1$ (d) $\sqrt{2} : 1$

Head office

fiziks, H.No. 40 D, G.F, Jia Sarai,
Near IIT, Hauz Khas, New Delhi-16
Phone: 011-26865455/+91-9871145498

Branch office

Anand Institute of Mathematics,
28-B/6, Jia Sarai, Near IIT
Hauz Khas, New Delhi-16