

## TIFR GS-2017 (Physics)

### Section A

Q1. Denote the commutator of two matrices  $A$  and  $B$  by  $[A, B] = AB - BA$  and the anticommutator by  $\{A, B\} = AB + BA$ .

If  $\{A, B\} = 0$ , we can write  $[ABC] =$

- (a)  $-B[A, C]$       (b)  $B\{A, C\}$       (c)  $[A, C]B$       (d)  $-B\{A, C\}$

Q2. Consider the waveform  $x(t)$  shown in the diagram below.

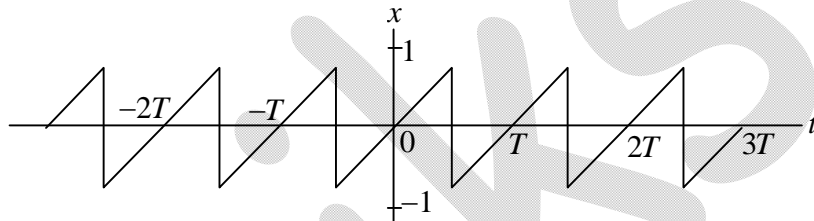

The Fourier series for  $x(t)$  which gives closest approximation to this waveform is

- (a)  $x(t) = \frac{2}{\pi} \left[ \cos \frac{\pi t}{T} - \frac{1}{2} \cos \frac{4\pi t}{T} + \frac{1}{3} \cos \frac{3\pi t}{T} + \dots \right]$
- (b)  $x(t) = \frac{2}{\pi} \left[ -\cos \frac{2\pi t}{T} + \frac{1}{2} \cos \frac{4\pi t}{T} - \frac{1}{3} \cos \frac{6\pi t}{T} + \dots \right]$
- (c)  $x(t) = \frac{2}{\pi} \left[ \sin \frac{\pi t}{T} - \frac{1}{2} \sin \frac{4\pi t}{T} + \frac{1}{3} \sin \frac{3\pi t}{T} + \dots \right]$
- (d)  $x(t) = \frac{2}{\pi} \left[ -\sin \frac{\pi t}{T} + \frac{1}{2} \sin \frac{2\pi t}{T} - \frac{1}{3} \sin \frac{3\pi t}{T} + \dots \right]$

#### Head office

fiziks, H.No. 40 D, G.F, Jia Sarai,  
Near IIT, Hauz Khas, New Delhi-16  
Phone: 011-26865455/+91-9871145498

#### Branch office

Anand Institute of Mathematics,  
28-B/6, Jia Sarai, Near IIT  
Hauz Khas, New Delhi-16

Q3. A solid tetrahedron (solid with four plane sides) has the following projections (drawn to scale) when seen from three different sides:

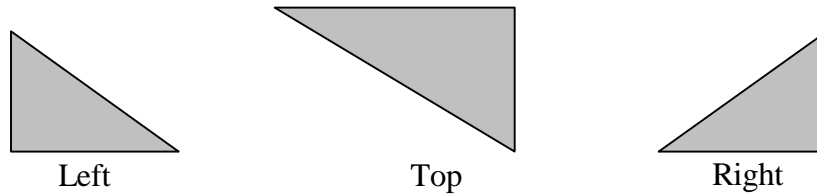

When viewed from the front, its projection will be

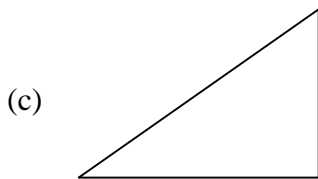
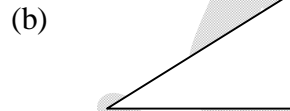
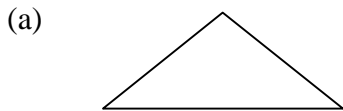

Q4. A small elastic ball of mass  $m$  is placed at the apex of a  $45^\circ$  inclined plane as shown in the figure below.

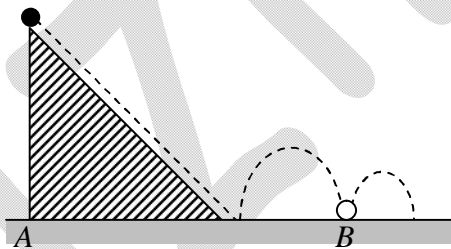

The ball is allowed to slip without friction down the plane (along the dotted line), hit the ground (as shown) and bounce along it. If the height of the inclined plane is  $h$  and the coefficient of restitution between the ball and the ground is 0.5, then the distance  $AB$ , as marked on the figure, will be

- (a)  $(1 + \sqrt{2})h$       (b)  $3\sqrt{2}h$       (c)  $3h$       (d)  $2h$

Q5. Two masses  $3m$  and  $2m$  are suspended vertically by identical massless springs, each of stiffness constant  $k$ . The mass  $2m$  is suspended from the mass  $3m$  and the mass  $3m$  is suspended from a rigid support, as shown in the figure. If only vertical motion is permitted, the frequencies of small oscillations of this system are

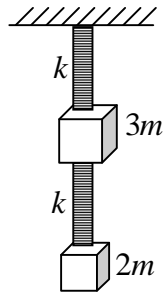

- (a)  $\sqrt{\frac{k}{m}}, \sqrt{\frac{3k}{2m}}$                       (b)  $\sqrt{\frac{k}{2m}}, \sqrt{\frac{k}{3m}}$   
 (c)  $\sqrt{\frac{k}{m}}, \sqrt{\frac{k}{6m}}$                       (d)  $\sqrt{\frac{2k}{3m}}, \sqrt{\frac{3k}{2m}}$

Q6. Two long hollow conducting cylinders, each of height  $h$ , are placed concentrically on the ground, as shown in the figure (top view). The outer cylinder is grounded, while the inner cylinder is insulated. A positive charge (the black dot in the figure) is placed between the

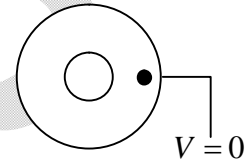

cylinders at a height  $\frac{h}{2}$  from the ground. Which of the following figures gives the most accurate representation (top view) of the lines of force?

- (a)                      (b)
- (c)                      (d)

**Head office**

fiziks, H.No. 40 D, G.F, Jia Sarai,  
 Near IIT, Hauz Khas, New Delhi-16  
 Phone: 011-26865455/+91-9871145498

**Branch office**

Anand Institute of Mathematics,  
 28-B/6, Jia Sarai, Near IIT  
 Hauz Khas, New Delhi-16

- Q7. A common model for the distribution of charge in a hydrogen atom has a point-like proton of charge  $+q_0$  at the centre and an electron with a static charge density distribution

$$\rho(r) = -\frac{q_0}{\pi a^3} e^{-\frac{2r}{a}}$$

where  $a$  is a constant. The electric field  $\vec{E}$  at  $r = a$  due to this system of charges will be

- (a)  $-\frac{5q_0}{4\pi\epsilon_0 e^2 a^2} \hat{r}$  (b)  $-\frac{5q_0}{4\pi\epsilon_0 e a^2} \hat{r}$   
 (c)  $\frac{3q_0}{4\pi\epsilon_0 e^2 a^2} \hat{r}$  (d)  $\frac{5q_0}{4\pi\epsilon_0 e^2 a^2} \hat{r}$

- Q8. A rectangular metallic loop with sides  $L_1$  and  $L_2$  is placed in the vertical plane, making an angle  $\phi$  with respect to the  $x$ -axis, as shown in the figure, and a spatially uniform magnetic field  $\vec{B} = B\hat{y}$  is applied. The loop is free to rotate about the  $\hat{z}$  axis (shown in the figure with a double line). The magnetic field changes with time at a constant rate

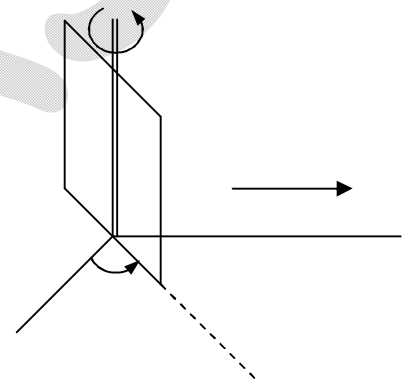

$$\frac{dB}{dt} = \kappa$$

If the resistance of the loop is  $R$ , the torque  $\tau$  required to prevent the loop from rotating will be

- (a)  $\kappa B \frac{(L_1 L_2)^2}{2R} \sin \phi \hat{z}$  (b)  $-\kappa B \frac{(L_1 L_2)^2}{2R} \sin 2\phi \hat{z}$   
 (c)  $\kappa B \frac{(L_1 L_2)^2}{R} \sin \phi \cos \phi \hat{z}$  (d)  $-\kappa B \frac{(L_1 L_2)^2}{R} \sin \phi \hat{z}$

**Head office**

fiziks, H.No. 40 D, G.F, Jia Sarai,  
 Near IIT, Hauz Khas, New Delhi-16  
 Phone: 011-26865455/+91-9871145498

**Branch office**

Anand Institute of Mathematics,  
 28-B/6, Jia Sarai, Near IIT  
 Hauz Khas, New Delhi-16

Q9. Consider the 1-D asymmetric double well potential  $V(x)$  as sketched below.

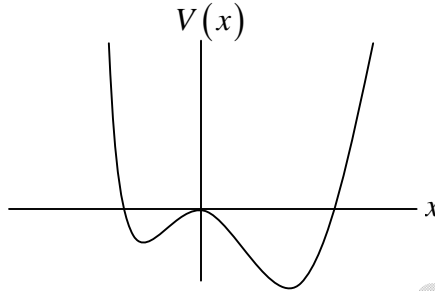

The probability distribution  $p(x)$  of a particle in the ground state of this potential is best represented by

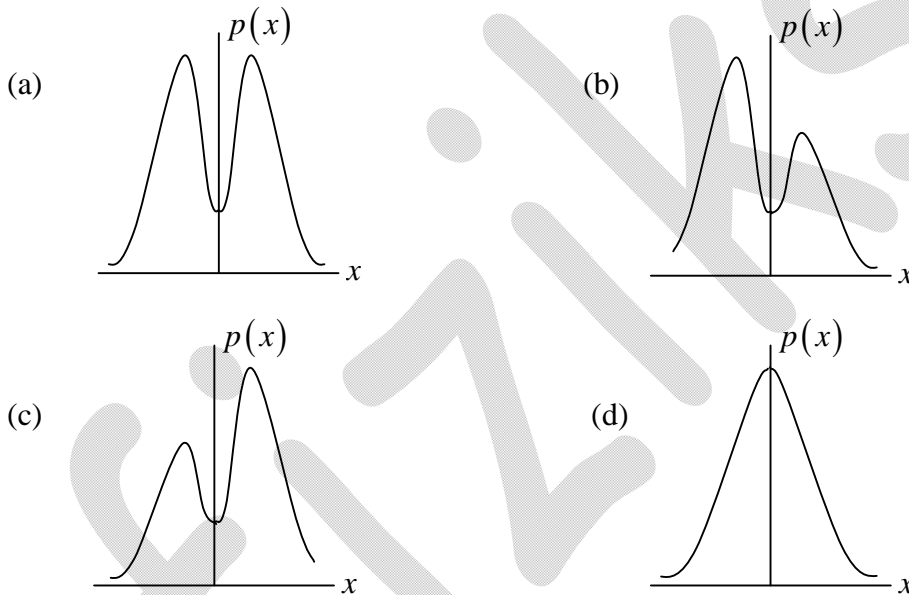

Q10. The normalized wave function of a particle can be written as

$$\psi(x) = N \sum_{n=0}^{\infty} \left( \frac{1}{\sqrt{7}} \right)^n \varphi_n(x)$$

where  $\varphi_n(x)$  are the normalized energy eigenfunctions of a given Hamiltonian. The value of  $N$  is

- (a)  $\sqrt{\frac{(6-2\sqrt{7})}{7}}$       (b)  $\sqrt{\frac{1}{7}}$       (c)  $\sqrt{\frac{3}{7}}$       (d)  $\sqrt{\frac{6}{7}}$

**Head office**

fiziks, H.No. 40 D, G.F, Jia Sarai,  
Near IIT, Hauz Khas, New Delhi-16  
Phone: 011-26865455/+91-9871145498

**Branch office**

Anand Institute of Mathematics,  
28-B/6, Jia Sarai, Near IIT  
Hauz Khas, New Delhi-16

Q11. Consider a system of non-interacting particles with integer angular momentum  $J$  at a temperature  $T$ . This system is placed in a magnetic field  $B$  in the  $z$  direction. The energy of a state with  $J_z = mh$  is

$$E_m = m\mu_B B$$

with  $\mu_B > 0$ . The fractional magnetization of the particles as a function of  $\frac{\mu_B B}{k_B T}$  can be

represented as

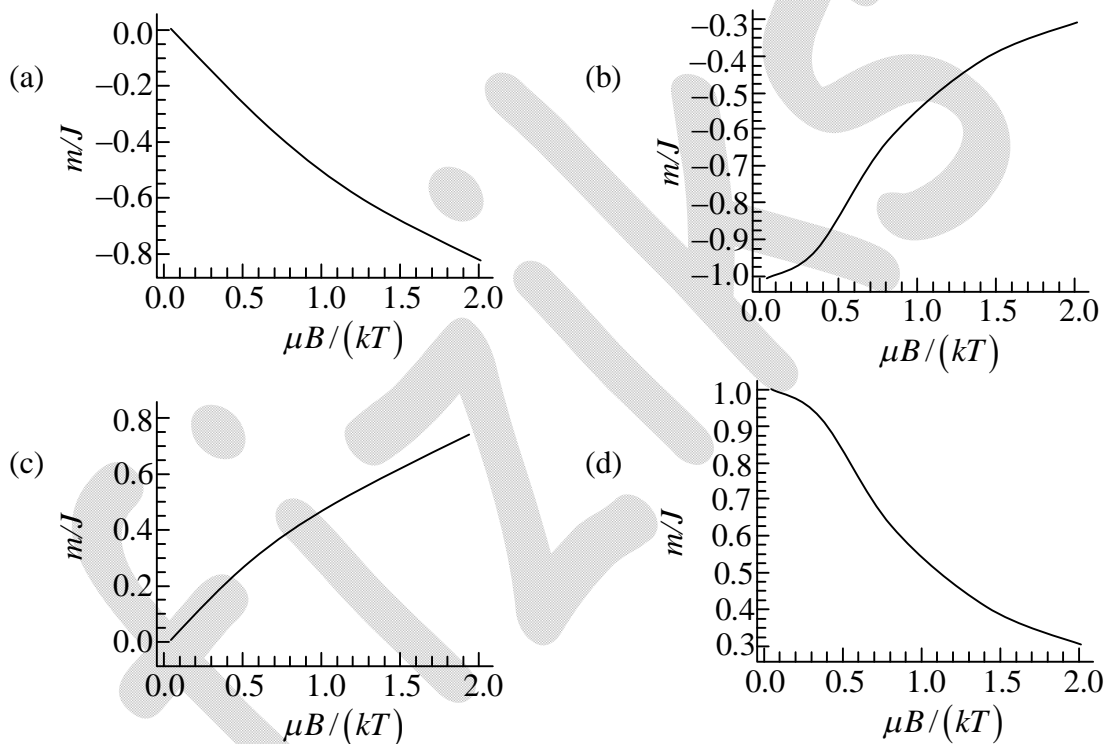

Q12. The separation between neighbouring absorption lines in a pure rotational spectrum of the hydrogen bromide ( $HBr$ ) molecule is  $2.23\text{ meV}$ . If this molecule is considered as a rigid rotor and the atomic mass number of  $Br$  is 80, the corresponding absorption line separation in deuterium bromide ( $DBr$ ) molecule, in units of  $\text{meV}$ , would be

- (a) 2.234                      (b) 1.115                      (c) 4.461                      (d) 1.128

**Head office**

fiziks, H.No. 40 D, G.F, Jia Sarai,  
Near IIT, Hauz Khas, New Delhi-16  
Phone: 011-26865455/+91-9871145498

**Branch office**

Anand Institute of Mathematics,  
28-B/6, Jia Sarai, Near IIT  
Hauz Khas, New Delhi-16

Q13. Consider a 2-D square lattice. The ratio of the kinetic energy of a free electron at a corner of the first Brillouin zone ( $E_c$ ) to that of an electron at the midpoint of a side

face-of the same zone ( $E_m$ ) is  $\frac{E_c}{E_m} =$

- (a) 2                      (b)  $\sqrt{2}$                       (c) 1                      (d)  $\frac{1}{2}$

Q14. A current source produces a square wave  $I(t)$  of 1.0V peak-to-peak voltage and is used to drive the RC circuit shown below.

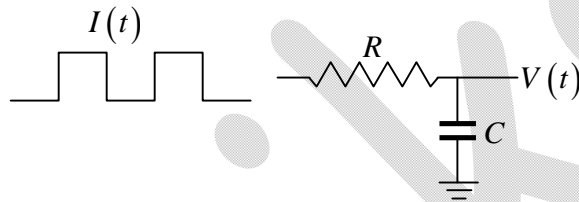

Which of the following represents the correct voltage across the capacitor  $C$  ?

- (a)                      (b)                      (c)                      (d)

Q15. The output ( $Y$ ) of the following circuit will be

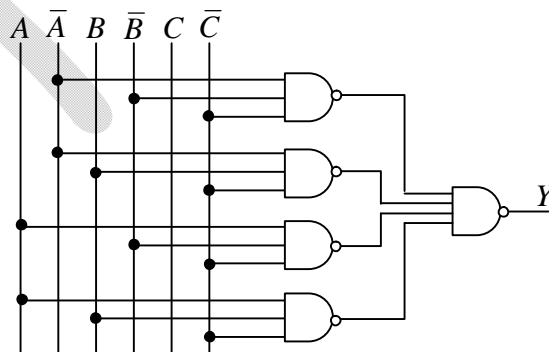

- (a)  $\bar{C}$                       (b)  $\bar{B}$                       (c)  $\bar{A}$                       (d)  $\bar{A} + B + \bar{C}$

**Head office**

fiziks, H.No. 40 D, G.F, Jia Sarai,  
Near IIT, Hauz Khas, New Delhi-16  
Phone: 011-26865455/+91-9871145498

**Branch office**

Anand Institute of Mathematics,  
28-B/6, Jia Sarai, Near IIT  
Hauz Khas, New Delhi-16

Q16. A space telescope in orbit around the Earth discovers a new planet, which is observed to move around the Sun by an angle of 4.72 milliradians in a year. Assuming a circular orbit, estimate the distance, in A.U., of the planet from the Sun.

Q17. The matrix

$$\begin{pmatrix} 100\sqrt{2} & x & 0 \\ -x & 0 & -x \\ 0 & x & 100\sqrt{2} \end{pmatrix}$$

where  $x > 0$ , is known to have two equal eigenvalues. Find the value of  $x$ .

Q18. A beam of plane microwaves of wavelength 12 cm strikes the surface of a dielectric at  $45^\circ$ . If the refractive index of the dielectric is  $\frac{4}{3}$ , what will be the wavelength, in units of mm, of the microwaves inside the dielectric?

Q19. A system of particles occupying single-particle levels and obeying Maxwell Boltzmann statistics is in thermal equilibrium with a heat reservoir at temperature  $T$ . If the population distribution in the non-degenerate energy levels is as shown in the table below, what would be the temperature of the system in degree Kelvin?

Energy (eV)	Population %
30.30	3.16
21.60	8.69
13.01	23.54
4.31	64.61

Q20. A thermally isolated container stores  $N_2$  gas at  $27.24^\circ C$  at one atmospheric pressure. Suddenly the pressure of the gas is increased to two atmospheric pressures. Assuming  $N_2$  to behave as an ideal gas, estimate the change in temperature of the gas, in Celsius degrees ( $^\circ C$ ).

**Head office**

fiziks, H.No. 40 D, G.F, Jia Sarai,  
Near IIT, Hauz Khas, New Delhi-16  
Phone: 011-26865455/+91-9871145498

**Branch office**

Anand Institute of Mathematics,  
28-B/6, Jia Sarai, Near IIT  
Hauz Khas, New Delhi-16



- Q21. A signal is to be sent from a coaxial cable with impedance  $40\Omega$  into a second coaxial cable with impedance  $60\Omega$ . We can prevent reflection at the joint between the cables, by adding an impedance in parallel to the second cable. What should be the value, in units of Ohms ( $\Omega$ ), of that impedance?
- Q22. An AC voltage source has an internal resistance of  $50\Omega$  and is specified to deliver an rms voltage of  $50V$  to a matched load. If you connect this AC source to a cathode-ray oscilloscope with  $1M\Omega$  input setting, what will be the peak-to-peak voltage you observe?
- Q23. The energy of an electron in the ground state of the He atom is  $-79eV$ . Considering the Bohr model of the atom, what would be 10 times the first ionization potential for a  $He^+$  ion, in units of  $eV$ ?
- Q24. A quantum mechanical system consists of a one-dimensional infinite box, as indicated in the figures below.

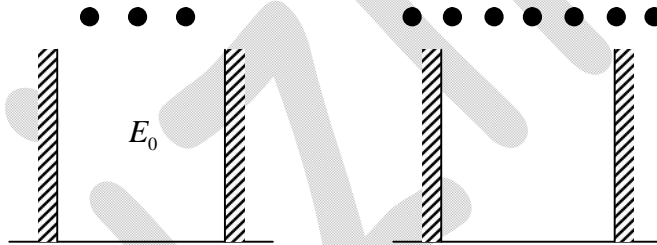

- 3 (three) identical non-interacting spin- $1/2$  particles; are first placed in the box, and the ground state energy of the system is found to be  $E_0 = 18eV$ . If 7 (seven) such identical particles are placed in the box, what will be the ground state energy, in units of  $eV$ ?
- Q25. Cosmic ray muons, which decay spontaneously with proper lifetime  $2.2\mu s$ , are produced in the atmosphere, at a height of  $5km$  above sea level. These move straight downwards at 98% of the speed of light.

Find the percent ratio  $100 \times \left( \frac{N_A}{N_B} \right)$  of the number of muons measured at the top of two mountains  $A$  and  $B$ , which are at heights  $4,848m$  and  $2,682m$  respectively above mean sea level.

**Head office**

fiziks, H.No. 40 D, G.F, Jia Sarai,  
Near IIT, Hauz Khas, New Delhi-16  
Phone: 011-26865455/+91-9871145498

**Branch office**

Anand Institute of Mathematics,  
28-B/6, Jia Sarai, Near IIT  
Hauz Khas, New Delhi-16

## SECTION B

Q26. A unitary matrix  $U$  is expanded in terms of a Hermitian matrix  $H$ , such that

$$U = e^{\frac{i\pi H}{2}}$$

if we know that

$$H = \begin{pmatrix} \frac{1}{2} & 0 & \frac{\sqrt{3}}{2} \\ 0 & 1 & 0 \\ \frac{\sqrt{3}}{2} & 0 & -\frac{1}{2} \end{pmatrix}$$

then  $U$  must be

(a)  $\begin{pmatrix} \frac{i}{2} & 0 & \frac{i\sqrt{3}}{2} \\ 0 & i & 0 \\ \frac{i\sqrt{3}}{2} & 0 & -\frac{i}{2} \end{pmatrix}$

(b)  $\begin{pmatrix} i & \frac{1}{2} & \frac{\sqrt{3}}{2} \\ \frac{1}{2} & i & \frac{1}{2} \\ \frac{\sqrt{3}}{2} & \frac{1}{2} & i \end{pmatrix}$

(c)  $\begin{pmatrix} 1 & 0 & \sqrt{3} \\ 0 & 2 & 0 \\ \sqrt{3} & 0 & -1 \end{pmatrix}$

(d)  $\begin{pmatrix} 2i & 1 & \frac{\sqrt{3}}{2} \\ 1 & 2i & 0 \\ \frac{\sqrt{3}}{2} & 0 & 2i \end{pmatrix}$

Q27. A liquid is flowing through a capillary tube of inner radius  $r$  under the influence of an external pressure  $P$ . The uncertainties in the measurements of  $P$  and  $r$  are found to be 2% and 1%, respectively. The uncertainty in the flow of liquid per second is

- (a) 3.61%                      (b) 2.23%                      (c) 2.83%                      (d) 4.47%

### Head office

fiziks, H.No. 40 D, G.F, Jia Sarai,  
Near IIT, Hauz Khas, New Delhi-16  
Phone: 011-26865455/+91-9871145498

### Branch office

Anand Institute of Mathematics,  
28-B/6, Jia Sarai, Near IIT  
Hauz Khas, New Delhi-16

- Q28. A uniform solid sphere  $S_1$  of radius  $r$  and mass  $m$  is rolling without slipping on top of another sphere  $S_2$  of radius  $R$ , as shown in the figure. Initially  $S_1$  was at rest directly on top of  $S_2$ , and then it started rolling down under the influence of gravity. The point of contact  $P$  subtends an instantaneous angle  $\theta$  from the topmost point  $N$  of the lower sphere at the centre of the lower sphere. At what minimum value of  $\theta$  will the spheres lose contact?

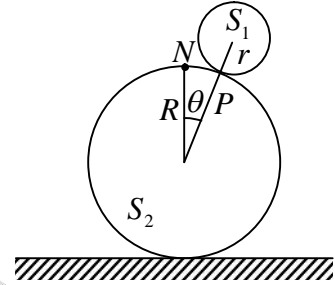

- (a)  $\cos^{-1} \frac{5}{13}$       (b)  $\cos^{-1} \frac{5}{12}$       (c)  $\cos^{-1} \frac{2}{3}$       (d)  $\cos^{-1} \frac{12}{13}$
- Q29. An electromagnetic wave in free space is described by

$$\vec{E}(x, y, z, t) = \hat{z} E_0 \cos \frac{1}{2} (kx - \sqrt{3}ky - 2\omega t)$$

The Poynting vector associated with this wave is along the direction

- (a)  $\hat{x} + \sqrt{3}\hat{y}$       (b)  $\sqrt{3}\hat{x} + \hat{y}$       (c)  $\hat{x} - \sqrt{3}\hat{y}$       (d)  $-\sqrt{3}\hat{x} + \hat{y}$
- Q30. Electrons in a given system of hydrogen atoms are described by the wave function

$$\psi(r, \theta, \varphi) = 0.8\psi_{100} + 0.6e^{i\pi/3}\psi_{311}$$

where the  $\psi_{nlm}$  denote normalized energy eigenstates. If  $(\hat{L}_x, \hat{L}_y, \hat{L}_z)$  are the components of the orbital angular momentum operator, the expectation value of  $\hat{L}_x^2$  in this system is

- (a)  $1.5\hbar^2$       (b)  $0.18\hbar^2$       (c)  $0.36\hbar^2$       (d) Zero
- Q31. In two dimensions, two metals  $A$  and  $B$ , have the number density of free electrons in the ratio

$$n_A : n_B = 1 : 2$$

The ratio of their Fermi energies is

- (a) 2:3      (b) 1:8      (c) 1:2      (d) 1:4

### Head office

fiziks, H.No. 40 D, G.F, Jia Sarai,  
Near IIT, Hauz Khas, New Delhi-16  
Phone: 011-26865455/+91-9871145498

### Branch office

Anand Institute of Mathematics,  
28-B/6, Jia Sarai, Near IIT  
Hauz Khas, New Delhi-16

Q32. One mole of monoatomic ideal gas is initially at pressure  $P_0$  and volume  $V_0$ .

The gas then undergoes a three-stage cycle consisting of- the following processes

- (i) An isothermal expansion till it reaches volume  $2V_0$ , and heat  $Q$  flows into the gas
- (ii) An isobaric compression back to the original volume  $V_0$
- (iii) An isochoric increase in pressure till the original pressure  $P_0$  is regained.

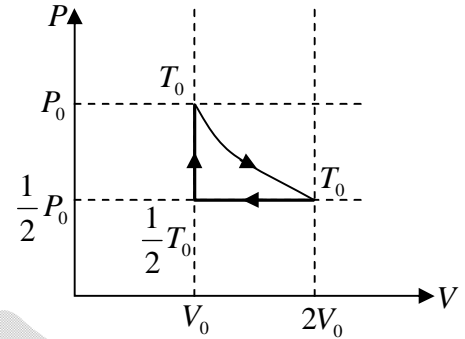

The efficiency of this cycle can be expressed as

- (a)  $\epsilon = \frac{4Q - 2RT_0}{4Q + 3RT_0}$
- (b)  $\epsilon = \frac{4Q + 2RT_0}{4Q - 3RT_0}$
- (c)  $\epsilon = \frac{4Q - 2RT_0}{4Q + RT_0}$
- (d)  $\epsilon = \frac{4Q + 2RT_0}{4Q + RT_0}$

Q33. A deuteron of mass  $M$  and binding energy  $B$  is struck by a gamma ray photon of energy  $E_\gamma$  and is observed to disintegrate into a neutron and a proton. If  $B \ll Mc^2$ , the minimum value of  $E_\gamma$  must be

- (a)  $2B + \frac{B^2}{2Mc^2}$
- (b)  $\frac{1}{2} \left( 3B + \frac{B^2}{Mc^2} \right)$
- (c)  $B + \frac{B^2}{Mc^2}$
- (d)  $\frac{1}{2} \left( 2B + \frac{B^2}{Mc^2} \right)$

Q34. Light passes through a narrow slit and gives the Fraunhofer diffraction pattern shown in the adjacent figure.

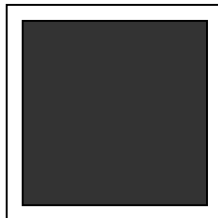

Which of the following could be the shape of the slit?

**Head office**

fiziks, H.No. 40 D, G.F, Jia Sarai,  
Near IIT, Hauz Khas, New Delhi-16  
Phone: 011-26865455/+91-9871145498

**Branch office**

Anand Institute of Mathematics,  
28-B/6, Jia Sarai, Near IIT  
Hauz Khas, New Delhi-16

- (a) 
- (b) 
- (c) 
- (d) 

Q35. For exact calculation and minimum complexity, two four-digit binary numbers can be added with

- (a) 3 full adders and 1 half-adder      (b) 2 full adders and 2 half-adders  
 (c) 1 full adder and 3 half-adders      (d) 4 full adders

Q36. Which digital logic gate is mimicked by the following silicon diode and silicon transistor circuit?

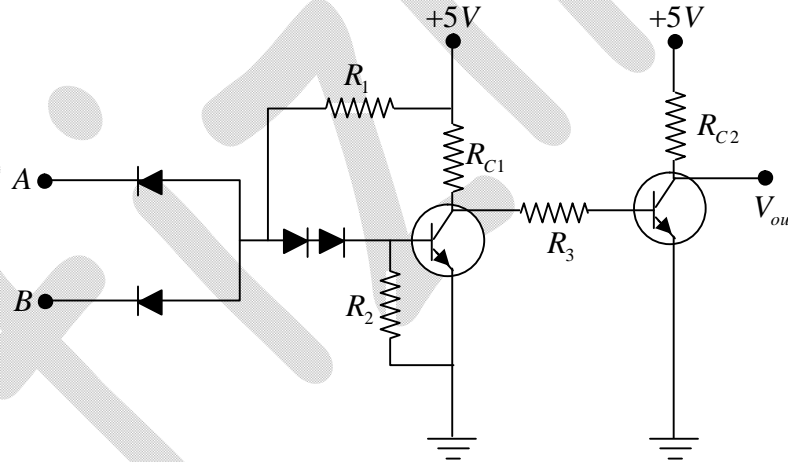

**Head office**

fiziks, H.No. 40 D, G.F, Jia Sarai,  
 Near IIT, Hauz Khas, New Delhi-16  
 Phone: 011-26865455/+91-9871145498

**Branch office**

Anand Institute of Mathematics,  
 28-B/6, Jia Sarai, Near IIT  
 Hauz Khas, New Delhi-16

Q37. Consider the following situations.

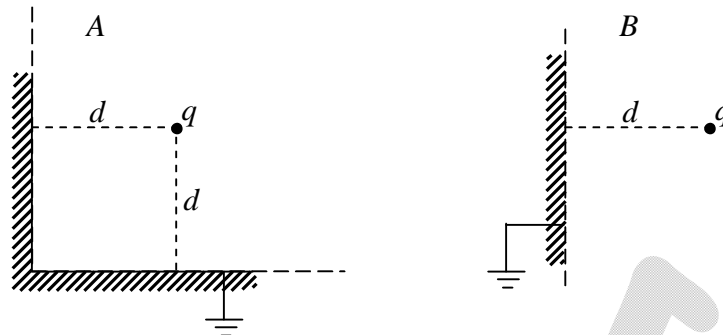

In situation  $A$ , two semi-infinite earthed conducting planes meet at right-angles. A point charge  $q$ , is placed at a distance  $d$  from each plane, as shown in the figure  $A$ . The magnitude of the force exerted on the charge  $q$  is denoted  $F_A$ .

In situation  $B$ , the same charge  $q$  is kept at the same distance  $d$  from an infinite earthed conducting plane, as shown in the figure  $B$ . The magnitude of the force exerted on the

charge  $q$  is denoted  $F_B$ . Find the numerical ratio  $\frac{F_A}{F_B}$

Q38. Two identical bosons may occupy any of two energy levels  $0, \varepsilon$ , where  $\varepsilon > 0$ . The lowest energy state is doubly-degenerate and the excited state is non-degenerate.

Assume that the two-particle system is in thermal equilibrium at a temperature  $T$ .

Calculate the average energy  $\langle E \rangle$ . What will be the leading term of

$$\frac{\langle E \rangle}{\exp\left(-\frac{\varepsilon}{k_B T}\right)}$$

at low temperature?

Q39. Evaluate the expression

$$n! \int_0^A dx_{n-1} \int_0^{x_{n-1}} dx_{n-2} \int_0^{x_{n-2}} dx_{n-3} \dots \int_0^{x_3} dx_2 \int_0^{x_2} dx_1 \int_0^{x_1} dx_0$$

### Head office

fiziks, H.No. 40 D, G.F, Jia Sarai,  
Near IIT, Hauz Khas, New Delhi-16  
Phone: 011-26865455/+91-9871145498

### Branch office

Anand Institute of Mathematics,  
28-B/6, Jia Sarai, Near IIT  
Hauz Khas, New Delhi-16

Q40. In outer space, where the effects of gravity can be neglected, a drop of liquid assumes a spherical shape. However, when disturbed it undergoes shape oscillations (see figure). The frequency  $\nu$  of oscillation of a drop depends on its equilibrium radius, its density and the surface tension.

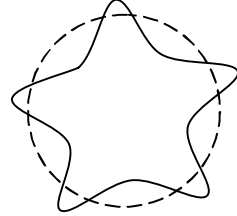

What would be the numerical value of the ratio  $\frac{\nu_{Hg}}{\nu_{H_2O}}$  of the frequencies of oscillation

between a drop of mercury ( $Hg$ ) and a drop of water ( $H_2O$ ) of the same equilibrium radius?

You may use the following data:

Liquid	Density in $gm\ cm^{-3}$	Surface tension in $Nm^{-1}$
Water	1.0	0.073
Mercury	13.6	0.487

Q41. The value of the integral

$$\int_0^{\infty} \frac{dx}{x^4 + 4}$$

is

- (a)  $\frac{\pi}{8}$       (b)  $\frac{\pi}{4}$       (c)  $\frac{\pi}{2}$       (d)  $\pi$

Q42. The Lagrangian of a system described by a single generalised coordinate  $q$  is

$$L = \frac{1}{2} \dot{q} \sin^2 q$$

Its Hamiltonian is

- (a) zero      (b)  $\dot{q} \left( p - \frac{1}{2} \sin^2 q \right)$   
 (c)  $-\dot{q} \sin^2 q$       (d) not defined

**Head office**

fiziks, H.No. 40 D, G.F, Jia Sarai,  
 Near IIT, Hauz Khas, New Delhi-16  
 Phone: 011-26865455/+91-9871145498

**Branch office**

Anand Institute of Mathematics,  
 28-B/6, Jia Sarai, Near IIT  
 Hauz Khas, New Delhi-16

Q43. A one-dimensional quantum harmonic oscillator of natural frequency  $\omega$  is in thermal equilibrium with a heat bath at temperature  $T$ . The mean value  $\langle E \rangle$  of the energy of the oscillator can be written as

- (a)  $\frac{\hbar\omega}{2} \coth\left(\frac{\hbar\omega}{2k_B T}\right)$                       (b)  $\frac{\hbar\omega}{2} \operatorname{csch}\left(\frac{\hbar\omega}{2k_B T}\right)$   
 (c)  $\frac{\hbar\omega}{2} \operatorname{sech}\left(\frac{\hbar\omega}{2k_B T}\right)$                       (d)  $\frac{\hbar\omega}{2} \tanh\left(\frac{\hbar\omega}{2k_B T}\right)$

Q44. Consider a spherical shell with radius  $R$  such that the potential on the surface of the shell in spherical coordinates is given by,

$$V(r = R, \theta, \varphi) = V_0 \cos^2 \theta$$

where the angle  $\theta$  is shown in the figure. There are no charges except for those on the shell. The potential outside the shell at the point  $P$  a distance  $2R$  away from its center  $C$  (see figure) is

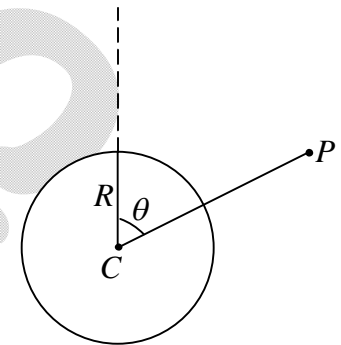

- (a)  $V = \frac{V_0}{8} (1 + 2\cos^2 \theta)$                       (b)  $V = \frac{V_0}{4} (1 - \cos^2 \theta)$   
 (c)  $V = \frac{V_0}{8} (1 + \cos^2 \theta)$                       (d)  $V = \frac{V_0}{2} (-2\cos \theta + \cos^3 \theta)$

Q45. A quantum mechanical system which has stationary states  $|1\rangle, |2\rangle$  and  $|3\rangle$ , corresponding to energy levels  $0eV, 1eV$  and  $2eV$  respectively, is perturbed by a potential of the form

$$\hat{V} = \varepsilon |1\rangle\langle 3| + \varepsilon |3\rangle\langle 1|$$

where, in  $eV, 0 < \varepsilon \ll 1$ .

The new ground state, correct to order  $\varepsilon$ , is approximately.

- (a)  $\left(1 - \frac{\varepsilon}{2}\right)|1\rangle + \frac{\varepsilon}{2}|3\rangle$                       (b)  $|1\rangle + \frac{\varepsilon}{2}|2\rangle - \varepsilon|3\rangle$   
 (c)  $|1\rangle - \frac{\varepsilon}{2}|3\rangle$                       (d)  $|1\rangle + \frac{\varepsilon}{2}|3\rangle$

### Head office

fiziks, H.No. 40 D, G.F, Jia Sarai,  
 Near IIT, Hauz Khas, New Delhi-16  
 Phone: 011-26865455/+91-9871145498

### Branch office

Anand Institute of Mathematics,  
 28-B/6, Jia Sarai, Near IIT  
 Hauz Khas, New Delhi-16



Q46. Hydrogen atoms in the atmosphere of a star are in thermal equilibrium, with an average kinetic energy of  $1eV$ . The ratio of the number of hydrogen atoms in the 2nd excited state ( $n=3$ ) to the number in the ground state ( $n=1$ ) is

- (a)  $5.62 \times 10^{-6}$  (b)  $3.16 \times 10^{-11}$   
 (c)  $3.16 \times 10^{-8}$  (d)  $1.33 \times 10^{-8}$

Q47. A photomultiplier tube is used to detect identical light pulses each of which consists of a fixed number of photons. The photoelectric efficiency is 10%, i.e. a photon has 10% probability of causing the emission of a detectable photo-electron.

The photomultiplier gain is  $10^6$ .

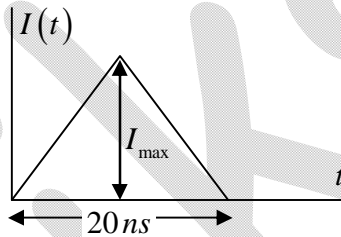

The typical output current, as a function of time, is shown by the figure below for a few pulses, where  $I_{\max}$  is  $80 \mu A$ . It follows that the number of photons in each pulse is

- (a)  $5 \times 10^6$  (b) 50 (c) 800 (d) 5

Q48. A subatomic particle  $\psi$  and its excited state  $\psi^*$  have rest masses  $3.1 GeV/c^2$  and  $3.7 GeV/c^2$  respectively. A table of its assigned quantum numbers is given below.

Angular Momentum	Parity	C-Parity	Isospin	Electric charge
$J = 1$	$P = -1$	$C = -1$	$I = 0$	$Q = 0$

If  $\pi^{0*}$  is an excited state of  $\pi^0$  with a mass of about  $1.3 GeV/c^2$ , which of the following reactions is possible when the above quantum numbers are conserved ?

- (a)  $\psi^* \rightarrow \gamma\gamma$  (b)  $\psi^* \rightarrow \pi^0\pi^0$   
 (c)  $\psi^* \rightarrow \psi\pi^+\pi^-$  (d)  $\psi^* \rightarrow \psi\pi^{0*}$

**Head office**

fiziks, H.No. 40 D, G.F, Jia Sarai,  
 Near IIT, Hauz Khas, New Delhi-16  
 Phone: 011-26865455/+91-9871145498

**Branch office**

Anand Institute of Mathematics,  
 28-B/6, Jia Sarai, Near IIT  
 Hauz Khas, New Delhi-16

- Q49. The cosmic microwave background radiation in the Universe has a blackbody distribution corresponding to a temperature  $2.735 K$ . In a certain cosmological model, it was assumed that the universe consists purely of radiation and is undergoing adiabatic expansion. In this model it was predicted that the volume of the Universe will be tripled in the next  $10^{10}$  yrs. The corresponding black body radiation temperature would be
- (a)  $0.9116 K$                       (b)  $2.078 K$                       (c)  $1.526 K$                       (d)  $1.896 K$

- Q50. The following circuit is fed with an input sine wave of frequency  $50 Hz$ .

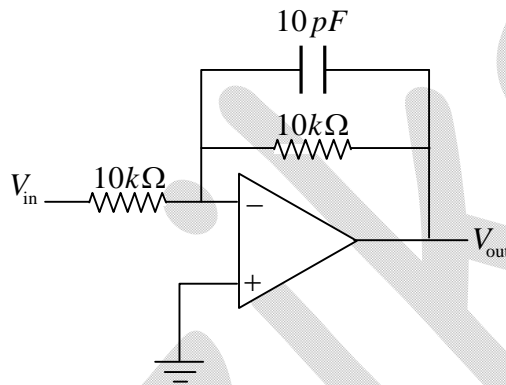

Which of the following graphs (solid line is input and dashed line is output) best represents the correct situation?

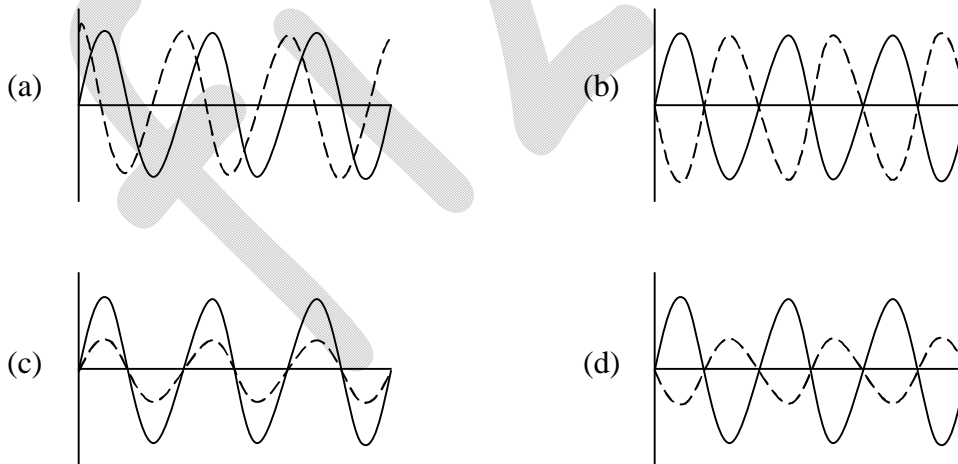

**Head office**

fiziks, H.No. 40 D, G.F, Jia Sarai,  
Near IIT, Hauz Khas, New Delhi-16  
Phone: 011-26865455/+91-9871145498

**Branch office**

Anand Institute of Mathematics,  
28-B/6, Jia Sarai, Near IIT  
Hauz Khas, New Delhi-16

Q51. Electrons in a metal are scattered by both impurities and phonons. The impurity scattering time is  $8 \times 10^{-12} \text{ s}$  and the phonon scattering time is  $2 \times 10^{-12} \text{ s}$ . Taking the density of electrons to be  $3 \times 10^{14} \text{ m}^{-3}$ , find the conductivity of the metal in units of  $\text{AV}^{-1}\text{m}^{-1}$ . [Assume that the effective mass of the electrons is the same as that of a free electron.]

Q52. A particle of mass  $m$ , confined to one dimension  $x$ , is in the ground state of a harmonic oscillator potential with a normalized wave function

$$\psi_0(x) = \left(\frac{2a}{\pi}\right)^{\frac{1}{4}} e^{-ax^2}$$

where  $a = \frac{m\omega}{2\hbar}$ . Find the expectation value of  $x^8$  in terms of the parameter  $a$

Q53. Write down  $x(t)$ , where  $x(t)$  is the solution of the following differential equation

$$\left(\frac{d}{dt} + 2\right)\left(\frac{d}{dt} + 1\right)x = 1,$$

with the boundary conditions

$$\left.\frac{dx}{dt}\right|_{t=0} = 0, \quad x(t)\Big|_{t=0} = -\frac{1}{2}$$

Q54. Assume that the crystal structure of metallic copper ( $\text{Cu}$ ) results in a density of atoms  $\rho_{\text{cu}} = 8.46 \times 10^{28} \text{ m}^{-3}$ . Each  $\text{Cu}$  atom in the crystal donates one electron to the conduction band, which leads, for the 3-D Fermi gas, to a density of states

$$g(\epsilon) = \frac{1}{2\pi^2} \left(\frac{2m^*}{\hbar^2}\right)^{\frac{3}{2}} \epsilon^{\frac{1}{2}}$$

where  $m^*$  is the effective mass of the conduction electrons. In the low temperature limit (i.e.  $T = 0 \text{ K}$ ), find the Fermi energy  $E_F$ , in units of  $eV$ . You may assume  $m^*$  to be equal to the free electron mass  $m_e$ .

## Head office

fiziks, H.No. 40 D, G.F, Jia Sarai,  
Near IIT, Hauz Khas, New Delhi-16  
Phone: 011-26865455/+91-9871145498

## Branch office

Anand Institute of Mathematics,  
28-B/6, Jia Sarai, Near IIT  
Hauz Khas, New Delhi-16

Q55. In a theoretical model of the nucleus, the binding energy per nucleon was predicted as shown in the figure below

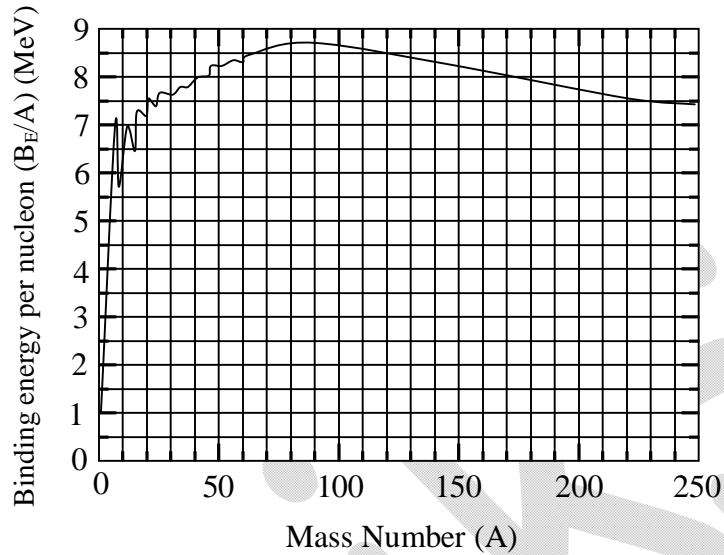

If a nucleus of mass number  $A = 240$  undergoes a symmetric fission to two daughter nuclei each of mass number  $A = 120$ , write down the amount of energy released in this process, in units of  $MeV$ , using this theoretical model.

**Head office**

fiziks, H.No. 40 D, G.F, Jia Sarai,  
Near IIT, Hauz Khas, New Delhi-16  
Phone: 011-26865455/+91-9871145498

**Branch office**

Anand Institute of Mathematics,  
28-B/6, Jia Sarai, Near IIT  
Hauz Khas, New Delhi-16