

GS-2012 (Physics)

TATA INSTITUTE OF FUNDAMENTAL RESEARCH

Written Test in **PHYSICS** - December 11, 2011

Duration: Three hours (3 hours)

Name: _____ Ref. Code: _____

Please read all instructions carefully before you attempt the questions.

1. Please fill-in details about name, reference code etc. on the question paper and answer sheet. The Answer Sheet is machine-readable. Read the instructions given on the reverse of the answer sheet before you start filling it up. Use only HB pencils to fill-in the answer sheet.

2. Indicate your ANSWER ON THE ANSWER SHEET by blackening the appropriate circle for each question. *Do not mark more than one circle for any question:* this will be treated as a wrong answer.

3. This test comes in two sections, **Section A** and **Section B**, both of which contain multiple choice-type questions. Only ONE of the options given at the end of each question is correct. Section A contains 20 questions, each with 4 options, and Section B contains 10 questions, each with 5 options. The maximum marks are 60 for Section A plus 40 for Section B, totaling to 100. Marking shall be as follows:

(i) If the answer is **correct**: +3 marks in Section A; +4 marks in Section B

(ii) If the answer is *incorrect*: -1 mark in both Section A & B

(iii) If the answer is **not attempted**: 0 marks in both Section A & B

(iv) If more than one box is **marked**: 0 marks in both Section A & B

Note that negative marking as indicated above will be implemented.

4. As a rough guideline, the time spent on questions in Section A should be about 5 minutes each; questions in Section B should take about 8 minutes each. Obviously, some questions may take a little less time while others may require a little more.
5. We advise you to first mark the correct answers on the QUESTION PAPER and then to TRANSFER these to the ANSWER SHEET only when you are sure of your choice.
6. Rough work may be done on blank pages of the question paper. If needed, you may ask for extra rough sheets from an Invigilator.
7. **Use of calculators is permitted.** Calculator which plots graphs is NOT allowed. Multiple-use devices such as cell phones, smart phones etc., CANNOT be used for this purpose.
8. Do NOT ask for clarifications from the invigilators regarding the questions. They have been instructed not to respond to any such inquiries from candidates. In case a Correction/clarification is deemed necessary; the invigilator(s) will announce it publicly.

GS-2012 (Physics)

A SECTION: 20 x 3= 60 Marks

A1. Two different 2×2 matrices A and B are found to have the same eigenvalues. It is then correct to state that $A = SBS^{-1}$ where S can be a

- (a) traceless 2×2 matrix (b) Hermitian 2×2 matrix
(c) unitary 2×2 matrix (d) arbitrary 2×2 matrix

A2. The function $f(x)$ represents the nearest integer less than x , e.g.

$$f(3.14) = 3.$$

The derivative of this function (for arbitrary x) will be given in terms of the integers n as

$$f'(x) =$$

- (a) 0 (b) $\sum_n \delta(x-n)$ (c) $\sum_n |x-n|$ (d) $\sum_n f(x-n)$

A3. Two masses M_1 and M_2 ($M_1 < M_2$) are suspended from a perfectly rigid horizontal support by a system of three taut massless wires W_1 , W_2 and W_3 , as shown in the figure. All the three wires have identical cross-sections and elastic properties and are known to be very strong.

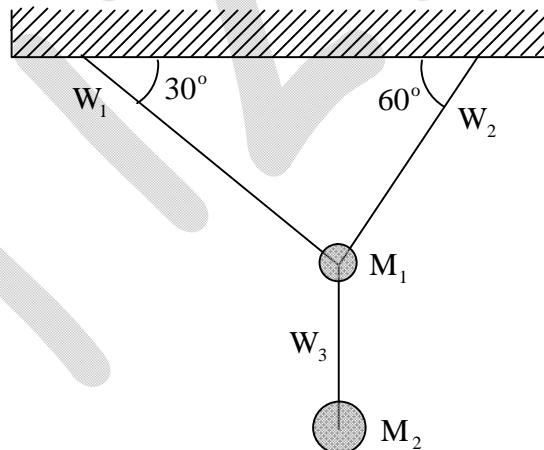

If the mass M_2 is increased gradually, but without limit, we should expect the wires to break in the following order:

- (a) first W_2 , then W_1 (b) first W_1 , then W_2
(c) first W_2 , then W_3 (d) first W_3

A4. A high-velocity missile, travelling in a horizontal line with a kinetic energy of 3.0 Giga-Joules (GJ), explodes in flight and breaks into two pieces A and B of equal mass. One of these pieces (A) flies off in a straight line perpendicular to the original direction in which the missile was moving and its kinetic energy is found to be 2.0 GJ. If gravity can be neglected for such high-velocity projectiles, it follows that the other piece (B) flew off in a direction at an angle with the original direction of

- (a) 30° (b) $33^\circ 24'$ (c) 45° (d) 60°

A5. Consider a spherical planet, rotating about an axis passing through its centre. The velocity of a point on its equator is v_{eq} . If the acceleration due to gravity g measured at the equator is half of the value of g measured at one of the poles, then the escape velocity for a particle shot upwards from that pole will be

- (a) $v_{eq}/2$ (b) $v_{eq}/\sqrt{2}$ (c) $\sqrt{2} v_{eq}$ (d) $2 v_{eq}$

A6. A dynamical system with two degrees of freedom, has generalized coordinates q_1 and q_2 , and kinetic energy

$$T = \lambda \dot{q}_1 \dot{q}_2$$

If the potential energy is $V(q_1, q_2) = 0$, the correct form of the Hamiltonian for this system is

- (a) $p_1 p_2 / \lambda$ (b) $\lambda \dot{q}_1 \dot{q}_2$
(c) $(p_1 \dot{q}_1 + p_2 \dot{q}_2) / 2$ (d) $(p_1 q_2 + p_2 q_1) / 2$

- A7. An ideal liquid of density 1 gm/cc is flowing at a rate of 10 gm/s through a tube with varying cross-section, as shown in the figure.

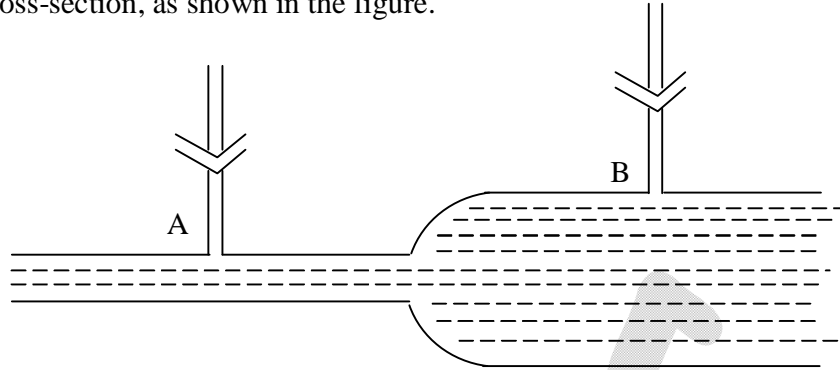

- Two pressure gauges attached at the points A and B (see figure) show readings of P_A and P_B respectively. If the radius of the tube at the points A and B is 0.2 cm and 1.0 cm respectively, then the difference in pressure ($P_B - P_A$), in units of dyne cm^{-2} , is closest to
- (a) 100 (b) 120 (c) 140 (d) 160

- A8. Unpolarised light of intensity I_0 passes successively through two identical linear polarisers A and B, placed such that their polarisation axes are at an angle of 45° (see figure) with respect to one another.

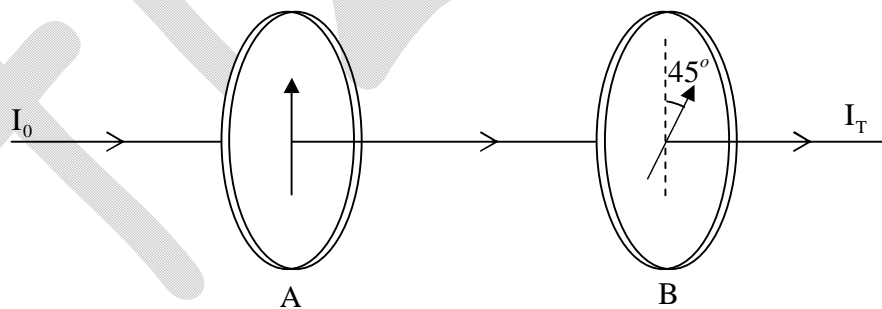

Assuming A and B to be perfect polarisers (i.e. no absorption losses), the intensity of the transmitted light will be $I_T =$

- (a) $I_0/4$ (b) $I_0/2\sqrt{2}$ (c) $I_0/2$ (d) $I_0/\sqrt{2}$

- A9. Three equal charges Q are successively brought from infinity and each is placed at one of the three vertices of an equilateral triangle. Assuming the rest of the Universe as a whole to be neutral, the energy E_0 of the electrostatic field will increase, successively, to

$$E_0 + \Delta_1, \quad E_0 + \Delta_1 + \Delta_2, \quad E_0 + \Delta_1 + \Delta_2 + \Delta_3$$

Where $\Delta_1 : \Delta_2 : \Delta_3 =$

- (a) 1 : 2 : 3 (b) 1 : 1 : 1 (c) 0 : 1 : 1 (d) 0 : 1 : 2
- A10. Five sides of a hollow metallic cube are grounded and the sixth side is insulated from the rest and is held at a potential Φ (see figure).

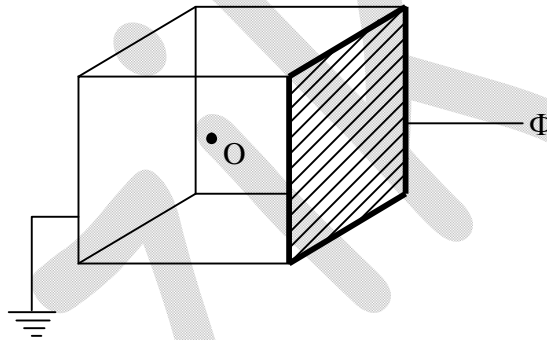

The potential at the center O of the cube is

- (a) 0 (b) $\Phi/6$ (c) $\Phi/5$ (d) $2\Phi/3$
- A11. Consider a sealed but thermally conducting container of total volume V , which is in equilibrium with a thermal bath at temperature T . The container is divided into two equal chambers by a thin but impermeable partition. One of these chambers contains an ideal gas, while the other half is a vacuum (see figure).

A14. A particle in a one-dimensional potential has the wavefunction

$$\varphi(x) = \frac{1}{\sqrt{a}} \exp\left(\frac{-|x|}{a}\right)$$

where a is a constant. It follows that for a positive constant V_0 , the potential $V(x) =$

- (a) $V_0 x^2$ (b) $V_0 |x|$ (c) $-V_0 \delta(x)$ (d) $-V_0/|x|$

A15. Consider the high excited states of a Hydrogen atom corresponding to large values of the principal quantum number ($n \gg 1$). The wavelength λ of a photon emitted due to an electron undergoing a transition between two such states with consecutive values of n (i.e. $\psi_{n+1} \rightarrow \psi_n$) is related to the wavelength λ_α of the K_α line of Hydrogen by

- (a) $\lambda = n^3 \lambda_\alpha/8$ (b) $\lambda = 3n^3 \lambda_\alpha/8$ (c) $\lambda = n^2 \lambda_\alpha$ (d) $\lambda = 4\lambda_\alpha/n^2$

A16. A proton is accelerated to a high energy E and shot at a nucleus of Oxygen ($^{16}_8\text{O}$). In order to penetrate the Coulomb barrier and reach the surface of the Oxygen nucleus, E must be at least

- (a) 3.6 MeV (b) 1.8 MeV (c) 45 keV (d) 180 eV

A17. A monochromatic beam of X-rays with wavelength λ is incident at an angle θ on a crystal with lattice spacings a and b as sketched in the figure below.

A condition for there to be a maximum in the diffracted X-ray intensity is

- (a) $2\sqrt{a^2 + b^2} \sin \theta = \lambda$
 (b) $2b \cos \theta = \lambda$
 (c) $2a \cos \theta = \lambda$
 (d) $(a + b) \sin \theta = \lambda$

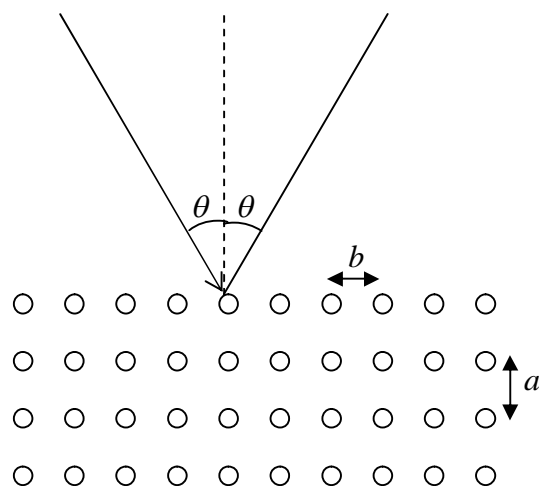

- A18. Suppose the energy band diagram of a certain pure crystalline solid is as shown in the figure below, where the energy (E) varies with crystal momentum (k) as $E \propto k^2$.

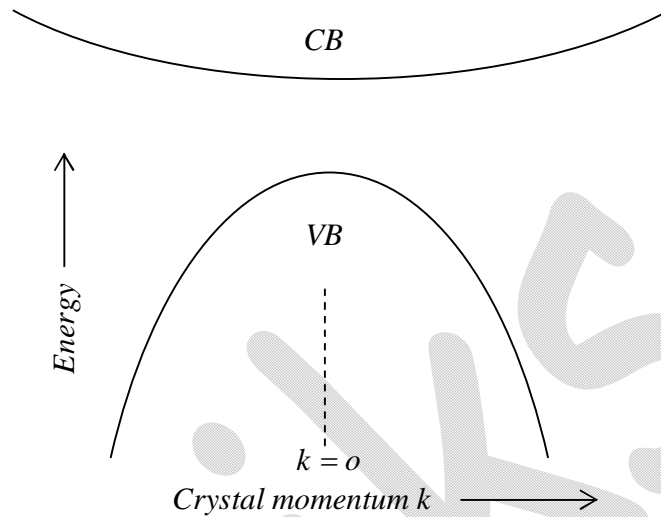

At finite temperatures the bottom of the conduction band (CB) is partially filled with electrons (e) and the top of the valence band (VB) is partially filled with holes (h). If an electric field is applied to this solid, both e and h will start moving. If the time between collisions is the same for both e and h , then

- (a) e and h will move with the same speed in opposite directions
 - (b) h will on an average achieve higher speed than e
 - (c) e will on an average achieve higher speed than h
 - (d) e and h will recombine and after a while there will be no flow of charges
- A19. Consider the circuit shown below.

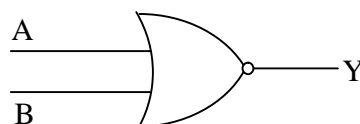

The minimum number of NAND gates required to design this circuit is

- (a) 6
- (b) 5
- (c) 4
- (d) 3

A20. Consider the following circuit:

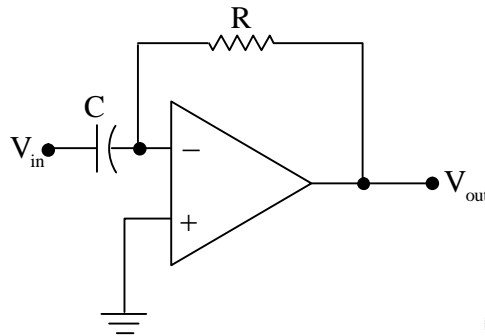

If the waveform given below is fed in at V_{in} ,

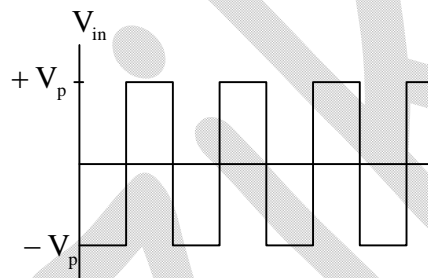

then the waveform at the output V_{out} will be

- (a) (b)
- (c) (d)

GS – 2012(PHYSIC)

B-Section (Marks 10x4=40)

B1. Consider the integral

$$\int_{-p^2}^{+p^2} \frac{dx}{\sqrt{x^2 - p^2}}$$

where p is a constant. This integral has a real, nonsingular value if

- (a) $p < -1$ (b) $p > 1$ (c) $p = 1$ (d) $p \rightarrow 0$ (e) $p \rightarrow \infty$

B2. If we model the electron as a uniform sphere of radius r_e , spinning uniformly about an axis passing through its centre with angular momentum $L_e = \hbar/2$, and demand that the velocity of rotation at the equator cannot exceed the velocity c of light in vacuum, then the minimum value of r_e is

- (a) 19.2 fm (b) 0.192 fm (c) 4.8 fm (d) 1960 fm (e) 480 fm

B3. The intensity of light coming from a distant star is measured using two identical instruments A and B , where A is placed in a satellite outside the Earth's atmosphere, and B is placed on the Earth's surface. The results are as follows:

Colour	Wavelength (nm)	Intensity at A (nanoWatts)	Intensity at B (nanoWatts)
green	500	100	50
red	700	200	x

Assuming that there is scattering, but no absorption of light in the Earth's atmosphere at these wavelengths, the value of x can be estimated as

- (a) 137 (b) 147 (c) 157 (d) 167 (e) 177

- B4. Consider three identical infinite straight wires A, B and C arranged in parallel on a plane as shown in the figure.

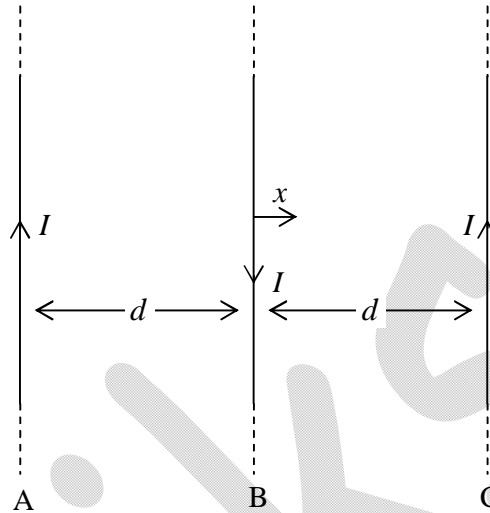

The wires carry equal currents I with directions as shown in the figure and have mass per unit length m . If the wires A and C are held fixed and the wire B is displaced by a small distance x from its position, then it (B) will execute simple harmonic motion with a time period

- (a) $2\pi\sqrt{\frac{m}{\pi\mu_0}}\left(\frac{d}{I}\right)$ (b) $2\pi\sqrt{\frac{2\pi m}{\mu_0}}\left(\frac{d}{I}\right)$ (c) $2\pi\sqrt{\frac{\pi m}{\mu_0}}\left(\frac{d}{I}\right)$
 (d) $2\pi\sqrt{\frac{m}{2\pi\mu_0}}\left(\frac{d}{I}\right)$ (e) $2\pi\sqrt{\frac{m}{\mu_0}}\left(\frac{d}{I}\right)$

- B5. The normalized wavefunctions of a Hydrogen atom are denoted by $\psi_{n,l,m}(\vec{x})$, where n , l and m are, respectively, the principal, azimuthal and magnetic quantum numbers respectively. Now consider an electron in the mixed state

$$\Psi(\vec{x}) = \frac{1}{3}\psi_{1,0,0}(\vec{x}) + \frac{2}{3}\psi_{2,1,0}(\vec{x}) + \frac{2}{3}\psi_{3,2,-2}(\vec{x})$$

The expectation value $\langle E \rangle$ of the energy of this electron, in electron-Volts (eV) will be approximately

- (a) -1.5 (b) -3.7 (c) -13.6 (d) -80.1 (e) +13.6

- B6. The strongest three lines in the emission spectrum of an interstellar gas cloud are found to have wavelengths λ_0 , $2\lambda_0$ and $6\lambda_0$ respectively, where λ_0 is a known wavelength. From this we can deduce that the radiating particles in the cloud behave like
- (a) free particles (b) particles in a box (c) harmonic oscillators
 (d) rigid rotators (e) hydrogenic atoms

- B7. When light is emitted from a gas of excited atoms, the lines in the spectrum are Doppler-broadened due to the thermal motion of the emitting atoms. The Doppler width of an emission line of wavelength 500 nanometres (nm) emitted by an excited atom of Argon (${}^{40}_{20}\text{A}$) at room temperature (27°C) can be estimated as
- (a) 5.8×10^{-4} nm (b) 3.2×10^{-4} nm (c) 3.2×10^{-3} nm
 (d) 2.5×10^{-3} nm (e) 1.4×10^{-3} nm

- B8. In a nuclear reactor, Plutonium (${}^{239}_{94}\text{Pu}$) is used as fuel, releasing energy by its fission into isotopes of Barium (${}^{146}_{54}\text{Ba}$) and Strontium (${}^{91}_{38}\text{Sr}$) through the reaction

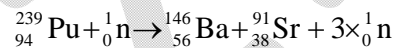

The binding energy (B.E.) per nucleon of each of these nuclides is given in the table below:

Nuclide	${}^{239}_{94}\text{Pu}$	${}^{146}_{54}\text{Ba}$	${}^{91}_{38}\text{Sr}$
B.E. per nucleon (MeV)	7.6	8.2	8.6

Using this information, one can estimate the number of such fission reactions per second in a 100 MW reactor as

- (a) 3.9×10^{18} (b) 7.8×10^{18} (c) 5.2×10^{19}
 (d) 5.2×10^{18} (e) 8.9×10^{17}

- B9. Metallic Copper is known to form cubic crystals and the lattice constant is measured from X-ray diffraction studies to be about 0.36 nm. If the specific gravity of Copper is 8.96 and its atomic weight is 63.5, one can conclude that
- (a) the crystals are of simple cubic type
 - (b) the crystals are of b.c.c. type
 - (c) the crystals are of f.c.c. type
 - (d) the crystals are a mixture of f.c.c. and b.c.c. types
 - (e) there is insufficient data to distinguish between the previous options
- B10. The voltage regulator circuit shown in the figure has been made with a Zener diode rated at 15V, 200mW. It is required that the circuit should dissipate 150mW power across the fixed load resistor R_L .

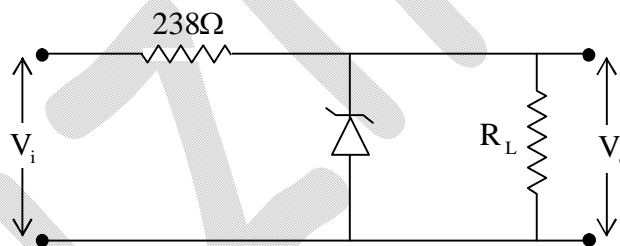

For stable operation of this circuit, the input voltage V_i must have a range

- (a) 17.5 V – 20.5 V
- (b) 15.5 V – 20.5 V
- (c) 15.5 V – 22.5 V
- (d) 17.5 V – 22.5 V
- (e) 15.0 V – 22.5 V