

IIT-JAM 2016

SECTION – A

MULTIPLE CHOICE QUESTIONS (MCQ)

Q1 – Q10 carry one mark each.

Q1. For an infinitely long wire with uniform line-charge density, λ along the z -axis, the electric field at a point $(a, b, 0)$ away from the origin is

(\hat{e}_x, \hat{e}_y and \hat{e}_z are unit vectors in Cartesian – coordinate system)

(a) $\frac{\lambda}{2\pi\epsilon_0\sqrt{a^2+b^2}}(\hat{e}_x + \hat{e}_y)$

(b) $\frac{\lambda}{2\pi\epsilon_0(a^2+b^2)}(a\hat{e}_x + b\hat{e}_y)$

(c) $\frac{\lambda}{2\pi\epsilon_0\sqrt{a^2+b^2}}\hat{e}_x$

(d) $\frac{\lambda}{2\pi\epsilon_0\sqrt{a^2+b^2}}\hat{e}_z$

Q2. A 1 W point source at origin emits light uniformly in all the directions. If the units for both the axes are measured in centimeter, then the Poynting vector at the point $(1, 1, 0)$ in $\frac{W}{cm^2}$ is

(a) $\frac{1}{8\pi\sqrt{2}}(\hat{e}_x + \hat{e}_y)$

(b) $\frac{1}{16\pi}(\hat{e}_x + \hat{e}_y)$

(c) $\frac{1}{16\pi\sqrt{2}}(\hat{e}_x + \hat{e}_y)$

(d) $\frac{1}{4\pi\sqrt{2}}(\hat{e}_x + \hat{e}_y)$

Q3. A charged particle in a uniform magnetic field $\vec{B} = B_0\hat{e}_z$ starts moving from the origin with velocity $\vec{v} = (3\hat{e}_x + 2\hat{e}_z)m/s$. The trajectory of the particle and the time t at which it reaches 2 meters above the xy -plane are

(\hat{e}_x, \hat{e}_y and \hat{e}_z are unit vectors in Cartesian-coordinate system)

(a) Helical path; $t = 1s$

(b) Helical path; $t = 2/3s$

(c) Circular path; $t = 1s$

(d) Circular path; $t = 2/3s$

Q4. Consider a particle of mass m following a trajectory given by $x = x_0 \cos \omega_1 t$ and $y = y_0 \sin \omega_2 t$, where x_0, y_0, ω_1 and ω_2 are constants of appropriate dimensions. The force on the particle is

(a) central only if $\omega_1 = \omega_2$

(b) central only if $x_0 = y_0$ and $\omega_1 = \omega_2$

(c) always central

(d) central only if $x_0 = y_0$ and $\omega_1 \neq \omega_2$

Head office

fiziks, H.No. 23, G.F, Jia Sarai,
Near IIT, Hauz Khas, New Delhi-16
Phone: 011-26865455/+91-9871145498

Branch office

Anand Institute of Mathematics,
28-B/6, Jia Sarai, Near IIT
Hauz Khas, New Delhi-16

Q5. Which of the following points represent the complex number $= \frac{1}{1-i}$?

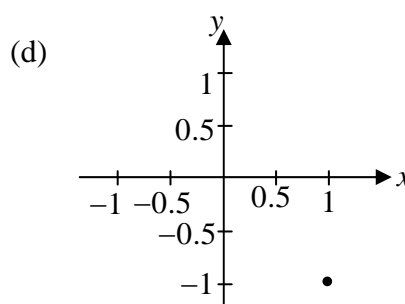
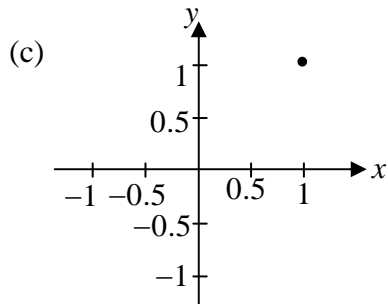
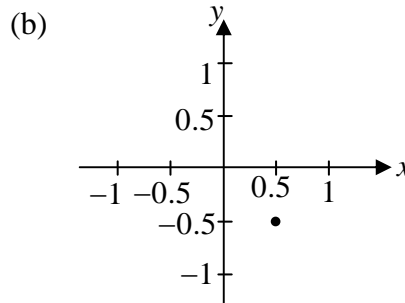
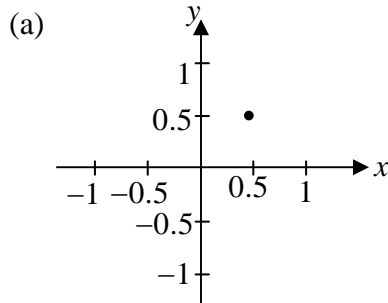

Q6. The eigenvalues of the matrix representing the following pair of linear equations

$$x + iy = 0$$

$$ix + y = 0$$

are

(a) $1+i, 1+i$

(b) $1-i, 1-i$

(c) $1, i$

(d) $1+i, 1-i$

Q7. The solution of the Boolean equation $Y = \overline{A + B} + \overline{AB}$ is

(a) 1

(b) \overline{AB}

(c) $\overline{A}\overline{B}$

(d) $\overline{A} + \overline{B}$

Head office

fiziks, H.No. 23, G.F, Jia Sarai,
Near IIT, Hauz Khas, New Delhi-16
Phone: 011-26865455/+91-9871145498

Branch office

Anand Institute of Mathematics,
28-B/6, Jia Sarai, Near IIT
Hauz Khas, New Delhi-16

Q8. A spherical closed container with smooth inner wall contains a monoatomic ideal gas. If the collisions between the wall and the atoms are elastic, then the Maxwell speed-distribution function $\left(\frac{dn_v}{dv}\right)$ for the atoms is best represented by:

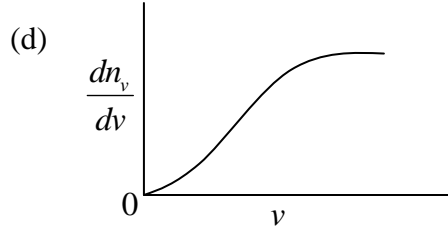
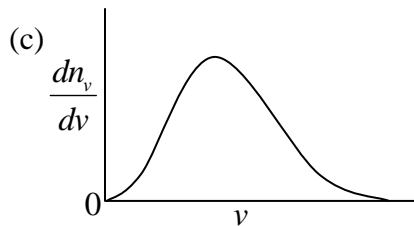
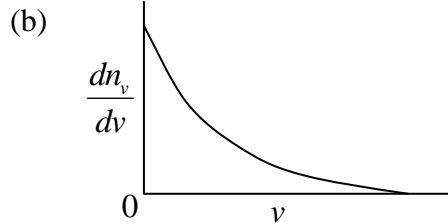
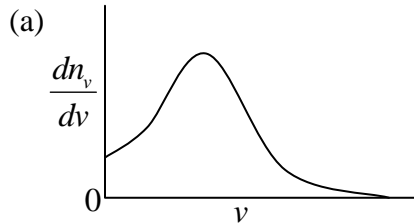

Q9. Two sinusoidal signals of frequency ω_x and ω_y having same amplitude are applied to x - and y - channels of a cathode ray oscilloscope (CRO), respectively. The following stationary figure will be observed when

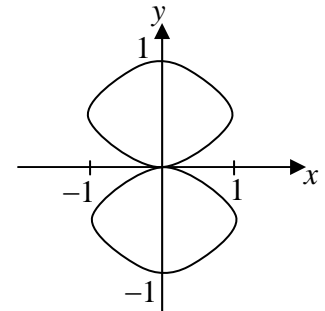

- (a) $\omega_y = \omega_x$ (b) phase difference is 0
 (c) $\omega_y = 2\omega_x$ (d) phase difference is $\pi/2$

Q10. The phase difference (δ) between input and output voltage for the following circuits (i) and (ii)

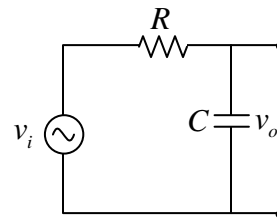
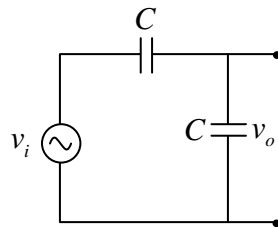

will be

- (a) 0 and 0 (b) $\pi/2$ and $0 < \delta \leq \pi/2$ respectively
 (c) $\pi/2$ and $\pi/2$ (d) 0 and $0 < \delta \leq \pi/2$ respectively

Head office

fiziks, H.No. 23, G.F, Jia Sarai,
 Near IIT, Hauz Khas, New Delhi-16
 Phone: 011-26865455/+91-9871145498

Branch office

Anand Institute of Mathematics,
 28-B/6, Jia Sarai, Near IIT
 Hauz Khas, New Delhi-16

Q11 – Q30 carry two marks each.

Q11. For the given set of equations

$$x + y = 1$$

$$y + z = 1$$

$$x + z = 1,$$

which one of the following statements is correct?

- (a) Equations are inconsistent
- (b) Equations are consistent and a single non-trivial solution exists
- (c) Equations are consistent and many solutions exist
- (d) Equations are consistent and only a trivial solution exists.

Q12. The tangent line to the curve $x^2 + xy + 5 = 0$ at $(1,1)$ is represented by

- (a) $y = 3x - 2$
- (b) $y = -3x + 4$
- (c) $x = 3y - 2$
- (d) $x = -3y + 4$

Q13. In the following RC circuit, the capacitor was charged in two different ways.

- (i) The capacitor was first charged to $5V$ by moving the toggle switch to position P and then it was charged to $10V$ by moving the toggle switch to position Q .
- (ii) The capacitor was directly charged to $10V$, by keeping the toggle switch at position Q .

Assuming the capacitor to be ideal, which one of the following statements is correct?

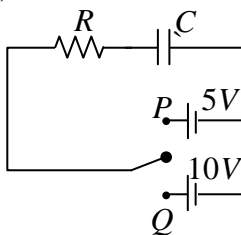

- (a) The energy dissipation in cases (i) and (ii) will be equal and non-zero.
- (b) The energy dissipation for case (i) will be more than that for case (ii)
- (c) The energy dissipation for case (i) will be less than that for case (ii)
- (d) The energy will not be dissipated in either case.

Head office

fiziks, H.No. 23, G.F, Jia Sarai,
Near IIT, Hauz Khas, New Delhi-16
Phone: 011-26865455/+91-9871145498

Branch office

Anand Institute of Mathematics,
28-B/6, Jia Sarai, Near IIT
Hauz Khas, New Delhi-16

Q18. For an ideal gas, which one of the following T - S diagram is valid?

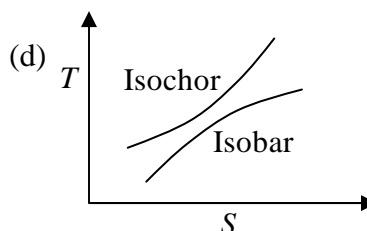
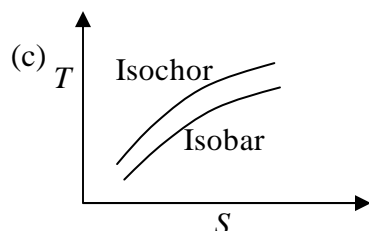
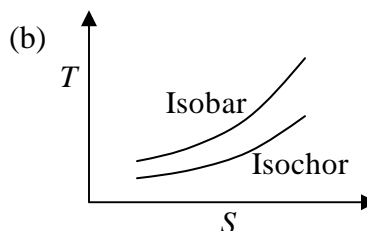
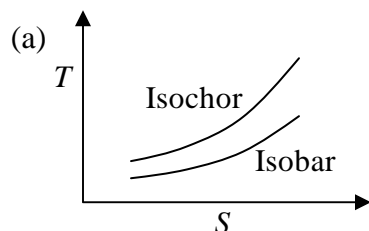

Q19. If U, F, H and G represent internal energy, Helmholtz free energy, enthalpy and Gibbs free energy respectively, then which one of the following is a correct thermodynamic relation?

(a) $dU = PdV - TdS$

(b) $dH = VdP + TdS$

(c) $dF = -PdV + SdT$

(d) $dG = VdP + SdT$

Q20. A train passes through a station with a constant speed. A stationary observer at the station platform measures the tone of the train whistle as 484 Hz when it approaches the station and 442 Hz when it leaves the station. If the sound velocity in air is 330 m/s , then the tone of the whistle and the speed of the train are

(a) $462\text{ Hz}, 54\text{ km/h}$

(b) $463\text{ Hz}, 52\text{ km/h}$

(c) $463\text{ Hz}, 56\text{ km/h}$

(d) $464\text{ Hz}, 52\text{ km/h}$

Q21. The minimum length of a plane mirror to see the entire full-length image of an object is half of the object's height. Suppose δ is the distance between eye and top of the head of a person of height h . The person will be able to see his entire full-length image with a mirror of height $h/2$ fixed on the wall

(a) when the bottom edge of mirror is kept $h/2$ above the floor

(b) when the bottom edge of mirror is kept $(h + \delta)/2$ above the floor

(c) when the bottom edge of mirror is kept $(h - \delta)/2$ above the floor

(d) when the centre of the mirror is at the same height as centre of the person

Head office

fiziks, H.No. 23, G.F, Jia Sarai,
Near IIT, Hauz Khas, New Delhi-16
Phone: 011-26865455/+91-9871145498

Branch office

Anand Institute of Mathematics,
28-B/6, Jia Sarai, Near IIT
Hauz Khas, New Delhi-16

Q22. A particle is moving in a plane with a constant radial velocity of 12 m/s and constant angular velocity of 2 rad/s . When the particle is at a distance $r = 8\text{ m}$ from the origin, the magnitude of the instantaneous velocity of the particle in m/s is

- (a) $8\sqrt{15}$ (b) 20 (c) $2\sqrt{37}$ (d) 10

Q23. A cylindrical rod of length L has a mass density distribution given by $\rho(x) = \rho_0 \left(1 + \frac{x}{L}\right)$, where x is measured from one end of the rod and ρ_0 is a constant of appropriate dimensions. The centre of mass of the rod is

- (a) $\frac{5}{9}L$ (b) $\frac{4}{9}L$ (c) $\frac{1}{9}L$ (d) $\frac{1}{2}L$

Q24. A particle travels in a medium along a horizontal linear path. The initial velocity of the particle is v_0 and the viscous force acting on it is proportional to its instantaneous velocity. In the absence of any other forces, which one of the following figures correctly represents the velocity of the particle as a function of time?

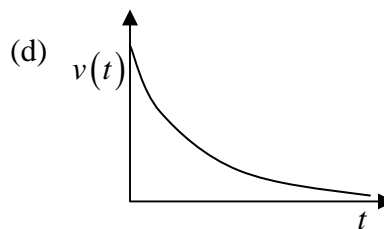
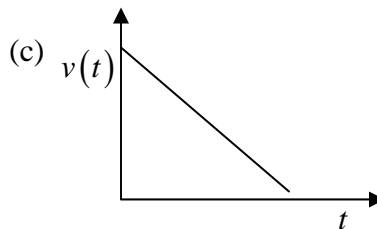
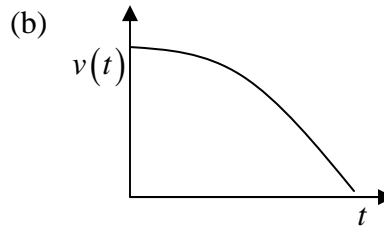
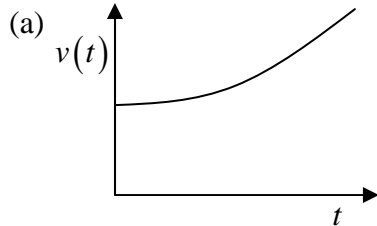

Head office

fiziks, H.No. 23, G.F, Jia Sarai,
Near IIT, Hauz Khas, New Delhi-16
Phone: 011-26865455/+91-9871145498

Branch office

Anand Institute of Mathematics,
28-B/6, Jia Sarai, Near IIT
Hauz Khas, New Delhi-16

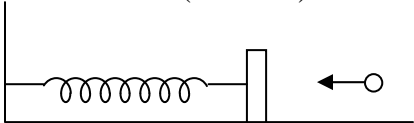
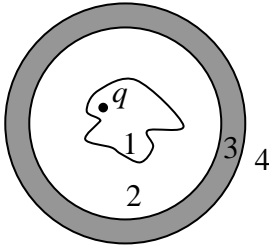
- Q25. A lightly damped harmonic oscillator with natural frequency ω_0 is driven by a periodic force of frequency ω . The amplitude of oscillation is maximum when
- ω is slightly lower than ω_0
 - $\omega = \omega_0$
 - ω is slightly higher than ω_0
 - The force is in phase with the displacement
- Q26. A block of mass 0.38 kg is kept at rest on a frictionless surface and attached to a wall with a spring of negligible mass. A bullet weighing 0.02 kg moving with a speed of 200 m/s hits the block at time $t = 0$ and gets stuck to it. The displacement of the block (in metre) with respect to the equilibrium position is given by
(Spring constant = 640 N/m)
- 
- $2 \sin 5t$
 - $\cos 10t$
 - $0.4 \cos 25t$
 - $0.25 \sin 40t$
- Q27. One mole of an ideal gas with average molecular speed v_0 is kept in a container of fixed volume. If the temperature of the gas is increased such that the average speed gets doubled, then
- the mean free path of the gas molecule will increase
 - the mean free path of the gas molecule will not change
 - the mean free path of the gas molecule will decrease
 - the collision frequency of the gas molecule with wall of the container remains unchanged.
- Q28. An arbitrarily shaped conductor encloses a charge q and is surrounded by a conducting hollow sphere as shown in the figure. Four different regions of space, 1, 2, 3 and 4 are indicated in the figure. Which one of the following statements is correct?
- 
- The electric field lines in region 2 are not affected by the position of the charge q
 - The surface charge density on the inner wall of the hollow sphere is uniform
 - The surface charge density on the outer surface of the sphere is always uniform irrespective of the position of charge q in region 1
 - The electric field in region 2 has a radial symmetry

Head office

fiziks, H.No. 23, G.F, Jia Sarai,
Near IIT, Hauz Khas, New Delhi-16
Phone: 011-26865455/+91-9871145498

Branch office

Anand Institute of Mathematics,
28-B/6, Jia Sarai, Near IIT
Hauz Khas, New Delhi-16

Q29. Consider a small bar magnet undergoing simple harmonic motion (SHM) along the x -axis. A coil whose plane is perpendicular to the x -axis is placed such that the magnet passes in and out of it during its motion. Which one of the following statements is correct? Neglect damping effects.

- (a) Induced e.m.f. is minimum when the center of the bar magnet crosses the coil
- (b) The frequency of the induced current in the coil is half of the frequency of the SHM
- (c) Induced e.m.f. in the coil will not change with the velocity of the magnet
- (d) The sign of the e.m.f. depends on the pole (N or S) face of the magnet which enters into the coil

Q30. An incompressible, non-viscous fluid is injected into a conical pipe at its orifice as schematically shown in the figure. The pressure at the orifice of area A_0 is P_0 . Neglecting the effect of gravity and assuming streamline flow, which one of the following plots correctly predicts the pressure along axis of the cone?

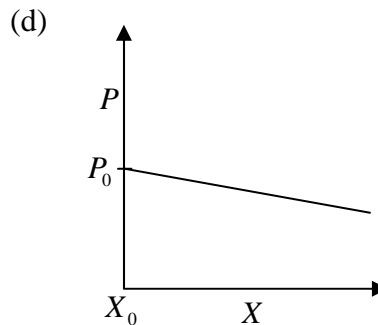
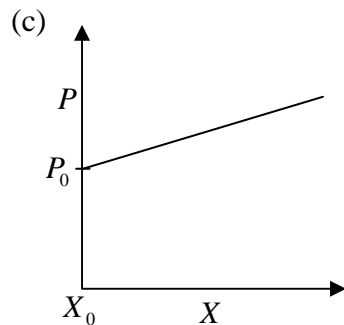
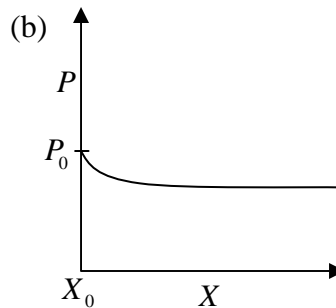
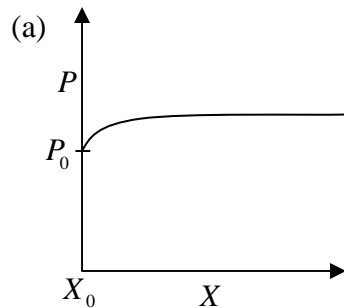
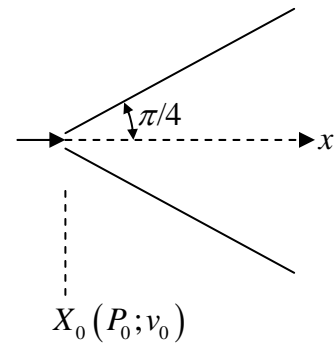

Head office

fiziks, H.No. 23, G.F, Jia Sarai,
Near IIT, Hauz Khas, New Delhi-16
Phone: 011-26865455/+91-9871145498

Branch office

Anand Institute of Mathematics,
28-B/6, Jia Sarai, Near IIT
Hauz Khas, New Delhi-16

SECTION – B

MULTIPLE SELECT QUESTIONS (MSQ)

Q31 - Q40 carry two marks each

Q31. Consider a spherical dielectric material of radius 'a' centered at origin. If the polarization vector,

$$\vec{P} = P_0 \hat{e}_x, \text{ where } P_0 \text{ is a constant of appropriate dimensions, then}$$

 $(\hat{e}_x, \hat{e}_y, \text{ and } \hat{e}_z \text{ are unit vectors in Cartesian- coordinate system})$

- (a) the bound volume charge density is zero.
 (b) the bound surface charge density is zero at $(0, 0, a)$.
 (c) the electric field is zero inside the dielectric
 (d) the sign of the surface charge density changes over the surface.

Q32. For an electric dipole with moment $\vec{P} = p_0 \hat{e}_z$ placed at the origin, (p_0 is a constant of appropriate dimensions and \hat{e}_x, \hat{e}_y and \hat{e}_z are unit vectors in Cartesian coordinate system)

- (a) potential falls as $\frac{1}{r^2}$, where r is the distance from origin
 (b) a spherical surface centered at origin is an equipotential surface
 (c) electric flux through a spherical surface enclosing the origin is zero
 (d) radial component of \vec{E} is zero on the xy - plane.

Q33. Three infinitely-long conductors carrying currents I_1, I_2 and I_3 lie perpendicular to the plane of the paper as shown in the figure.

If the value of the integral $\oint_C \vec{B} \cdot d\vec{l}$ for the loops C_1, C_2 and

C_3 are $2\mu_0, 4\mu_0$ and μ_0 in the units of $\frac{N}{A}$ respectively, then

- (a) $I_1 = 3A$ into the paper
 (b) $I_2 = 5A$ out of the paper
 (c) $I_3 = 0$.
 (d) $I_3 = 1A$ out of the paper

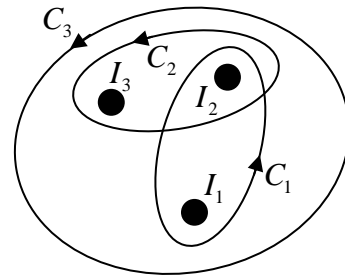
**Head office**

fiziks, H.No. 23, G.F, Jia Sarai,
 Near IIT, Hauz Khas, New Delhi-16
 Phone: 011-26865455/+91-9871145498

Branch office

Anand Institute of Mathematics,
 28-B/6, Jia Sarai, Near IIT
 Hauz Khas, New Delhi-16

Q34. In the optical arrangement as shown below, the axes of two polarizing sheets P and Q are oriented such that no light is detected. Now when a third polarizing sheet (R) is placed in between P and Q , then light is detected. Which of the following statement (s) is (are) true?

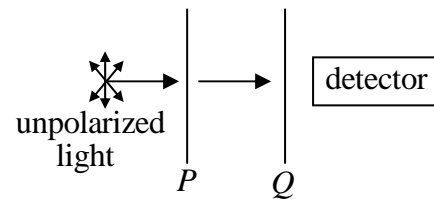

- (a) Polarization axes of P and Q are perpendicular to each other.
- (b) Polarization axis of R is not parallel to P
- (c) Polarization axis of R is not parallel to Q
- (d) Polarization axes of P and Q are parallel to each other.

Q35. The P - V diagram below shows three possible paths for an ideal gas to reach the final state f from an initial state i . Which among the following statements (s) is (are) correct?

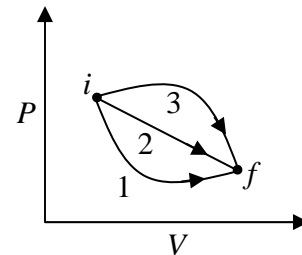

- (a) The work done by the gas is maximum along path -3.
- (b) Minimum change in the internal energy occurs along path -2.
- (c) Maximum heat transfer is for path -1
- (d) Heat transfer is path independent

Q36. Potential energy U as a function of r is shown below. If a particle of mass m_1 and energy E_1 , starting from $r \gg a$, moves towards the origin, then

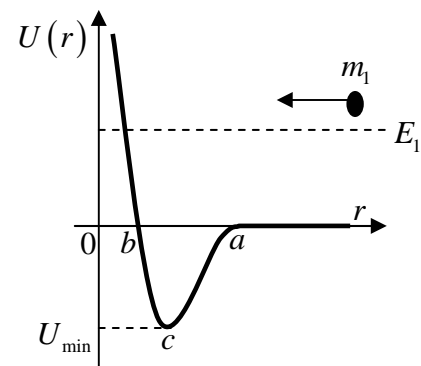

- (a) there is only one turning point for the particle
- (b) velocity of the particle starts to increase at $r = a$ and reaches its maximum at $r = c$
- (c) velocities of the particle at $r = a$ and $r = b$ are equal
- (d) the particle gets bounded if it elastically collides with a stationary particle of mass m_2 at $r = c$, imparting a momentum greater than $\sqrt{2m_2 E_1}$

Head office

fiziks, H.No. 23, G.F, Jia Sarai,
Near IIT, Hauz Khas, New Delhi-16
Phone: 011-26865455/+91-9871145498

Branch office

Anand Institute of Mathematics,
28-B/6, Jia Sarai, Near IIT
Hauz Khas, New Delhi-16

- Q37. A particle moves in a circular path in the xy -plane centered at the origin. If the speed of the particle is constant, then its angular momentum
- about the origin is constant both in magnitude and direction
 - about $(0,0,1)$ is constant in magnitude but not in direction
 - about $(0,0,1)$ varies both in magnitude and direction
 - about $(0,0,1)$ is constant in direction but not in magnitude
- Q38. A pn junction was formed with a heavily doped $(10^{18} \text{ cm}^{-3})$ p -region and lightly doped $(10^{14} \text{ cm}^{-3})$ n -region. Which of the following statement (s) is (are) correct?
- The width of the depletion layer will be more in the n -side of the junction
 - The width of the depletion layer will be more in the p -side of the junction
 - The width of the depletion layer will be same on the both side of the junction
 - If the pn junction is reverse biased, then the width of the depletion region increase
- Q39. A slit has width ' d ' along the x -direction. If a beam of electrons, accelerated in y -direction to a particular velocity by applying a potential difference of $100 \pm 0.1 \text{ kV}$ passes through the slit, then, which of the following statement (s) is (are) correct?
- The uncertainty in the position of the electrons in x -direction before passing the slit.
 - The momentum of electrons in x -direction is $\sim \frac{\hbar}{d}$ immediately after passing the slit
 - The uncertainty in the position of electrons in y -direction before passing the list is zero
 - The presence of the slit does not affect the uncertainty in momentum of electrons in y -direction
- Q40. A free particle of energy E collides with a one-dimensional square potential barrier of height V and width W . Which one of the following statement(s) is/are correct?
- For $E > V$, the transmission coefficient for the particle across the barrier will always be unity
 - For $E < V$, the transmission coefficient changes more rapidly with W than with V
 - For $E < V$, if V is doubled, the transmission coefficient will also be doubled.
 - Sum of the reflection and the transmission coefficients is always one

Head office

fiziks, H.No. 23, G.F, Jia Sarai,
Near IIT, Hauz Khas, New Delhi-16
Phone: 011-26865455/+91-9871145498

Branch office

Anand Institute of Mathematics,
28-B/6, Jia Sarai, Near IIT
Hauz Khas, New Delhi-16

SECTION – C

NUMERICAL ANSWER TYPE (NAT)

Q41 – Q50 carry one mark each.

Q41. Fourier series of a given function $f(x)$ in the interval 0 to L is

$$f(x) = \frac{a_0}{2} + \sum_{n=1}^{\infty} a_n \cos\left(\frac{2\pi nx}{L}\right) + \sum_{n=1}^{\infty} b_n \sin\left(\frac{2\pi nx}{L}\right).$$

If $f(x) = x$ in the region $(0, \pi)$, $b_2 =$ _____

Q42. Consider a function $f(x, y) = x^3 + y^3$, where y represents a parabolic curve $x^2 + 1$. The total derivative of f with respect to x , at $x = 1$ is _____.

Q43. A rectangular area (A_1) is formed by two vectors \vec{x} and \vec{y} as shown in figure (i). A new set of vectors, representing the area (A_2) as shown in figure (ii), are given as: $\vec{u}_1 = \vec{x}$; $\vec{u}_2 = k\vec{x} + \vec{y}$, where k is a dimensionless constant.

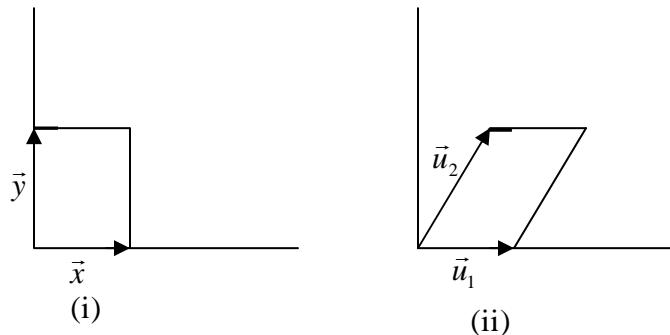

The Jacobian of the frame (\vec{u}_1, \vec{u}_2) with respect to (\vec{x}, \vec{y}) is _____.

Q44. A particular radioisotope has a half-life of 5 days. In 15 days the probability of decay in percentage will be _____.

Q45. In photoelectric experiment both sodium (work function = 2.3 eV) and tungsten (work function = 4.5 eV) metals were illuminated by an ultraviolet light of same wavelength. If the stopping potential for tungsten is measured to be 1.8 V , the value of the stopping potential for sodium will be _____ V.

Q46. The addition of two binary numbers 1000.01 and 0001.11 in binary representation is _____

Head office

fiziks, H.No. 23, G.F, Jia Sarai,
Near IIT, Hauz Khas, New Delhi-16
Phone: 011-26865455/+91-9871145498

Branch office

Anand Institute of Mathematics,
28-B/6, Jia Sarai, Near IIT
Hauz Khas, New Delhi-16

- Q47. The number of second-nearest neighbor ions to a Na^+ ion in NaCl crystal is _____.
- Q48. The output voltage V_o of the OPAMP circuit given below is _____ V

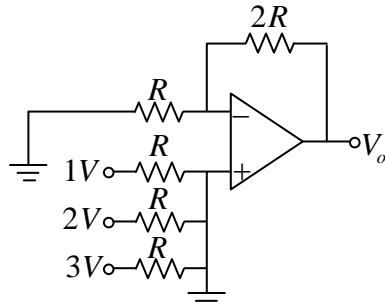

- Q49. A cylinder contains 16 g of O_2 . The work done when the gas is compressed to 75% of the original volume at constant temperature of 27°C is _____ J.

[Universal gas constant $R = 8.31\text{ J}/(\text{mole K})$]

- Q50. When sunlight is focused on a paper using a bi-convex lens, it starts to burn in the shortest time if the lens is kept 0.5 m above it. If the radius of curvature of the lens is 0.75 m then, the refractive index of the material is _____.

Q51 – Q60 carry two marks each.

- Q51. Consider a closed triangular contour traversed in counter-clockwise direction, as shown in the figure.

The value of the integral, $\oint \vec{F} \cdot d\vec{l}$ evaluated along this contour, for a vector field, $\vec{F} = y\hat{e}_x - x\hat{e}_y$, is _____ (\hat{e}_x, \hat{e}_y and \hat{e}_z are unit vectors in Cartesian-coordinate system).

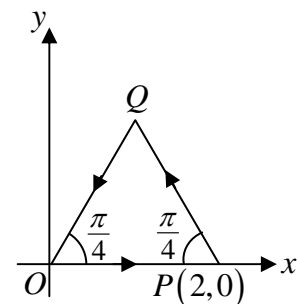

- Q52. A hemispherical shell is placed on the xy -plane centered at the origin. For a vector field $\vec{E} = (-y\hat{e}_x + x\hat{e}_y)/(x^2 + y^2)$, the value of the integral $\int_S (\vec{\nabla} \times \vec{E}) \cdot d\vec{a}$ over the hemispherical surface is _____ π .

($d\vec{a}$ is the elemental surface area, \hat{e}_x, \hat{e}_y and \hat{e}_z are unit vectors in Cartesian-coordinate system)

- Q53. The shape of a dielectric lamina is defined by the two curves $y = 0$ and $y = 1 - x^2$. If the charge density of the lamina $\sigma = 15y\text{ C}/\text{m}^2$, then the total charge on the lamina is _____ C.

Head office

fiziks, H.No. 23, G.F, Jia Sarai,
Near IIT, Hauz Khas, New Delhi-16
Phone: 011-26865455/+91-9871145498

Branch office

Anand Institute of Mathematics,
28-B/6, Jia Sarai, Near IIT
Hauz Khas, New Delhi-16

Q54. In the circuit given below, the collector to emitter voltage V_{CE} is _____ V .

(Neglect V_{BE} , take $\beta = 100$)

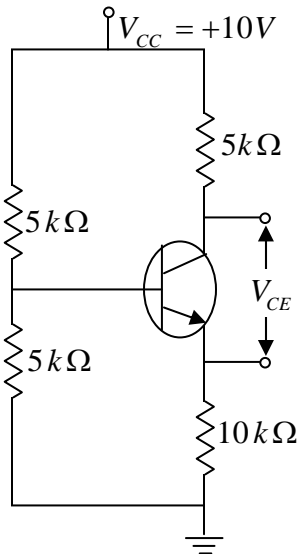

Q55. The de Broglie wavelength of a relativistic electron having 1 MeV of energy is _____ $\times 10^{-12}$ m .

(Take the rest mass energy of the electron to be 0.5 MeV . Plank constant = 6.63×10^{-34} Js , speed of light = 3×10^8 m/s , Electronic charge = 1.6×10^{-19} C)

Q56. X -ray diffraction of a cubic crystal gives an intensity maximum for Bragg angle 20° corresponding to the (110) plane. The lattice parameter of the crystal is _____ nm .

(Consider wavelength of X - ray = 0.15 nm)

Q57. X -ray of 20 keV energy is scattered inelastically from a carbon target. The kinetic energy transferred to the recoiling electron by photons scattered at 90° with respect to the incident beam is _____ keV .

(Planck constant = 6.6×10^{-34} Js, Speed of light = 3×10^8 m/s, electron mass = 9.1×10^{-31} kg. Electronic charge = 1.6×10^{-19} C)

Head office

fiziks, H.No. 23, G.F, Jia Sarai,
Near IIT, Hauz Khas, New Delhi-16
Phone: 011-26865455/+91-9871145498

Branch office

Anand Institute of Mathematics,
28-B/6, Jia Sarai, Near IIT
Hauz Khas, New Delhi-16

- Q58. An aluminum plate of mass 0.1 kg at 95°C is immersed in 0.5 litre of water at 20°C kept inside an insulating container and is then removed. If the temperature of the water is found to be 23°C , then the temperature of the aluminum plate is _____ $^\circ\text{C}$
(The specific heat of water and aluminum are 4200 J/kg-K and 900 J/kg-K respectively, the density of water is 1000 kg/m^3)
- Q59. The maximum and minimum speeds of a comet that orbits the Sun are 80 and 10 km/s respectively. The ratio of the aphelion distance of the comet to the radius of the Earth's orbit is _____.
(Assume that Earth moves in a circular orbit of radius $1.5 \times 10^8 \text{ km}$ with a speed of 30 km/s)
- Q60. If there is a 10% decrease in the atmospheric pressure at a hill compared to the pressure at sea level, then the change in the boiling point of water is _____ $^\circ\text{C}$
(Take latent heat of vaporisation of water as 2270 kJ/kg and the change in the specific volume at the boiling point to be $1.2 \text{ m}^3/\text{kg}$)

Head office

fiziks, H.No. 23, G.F, Jia Sarai,
Near IIT, Hauz Khas, New Delhi-16
Phone: 011-26865455/+91-9871145498

Branch office

Anand Institute of Mathematics,
28-B/6, Jia Sarai, Near IIT
Hauz Khas, New Delhi-16