



Physics by fiziks

Learn Physics in Right Way

Physics by fiziks

TIFR Physics

Question Paper -2024

Learn Physics in Right Way

**Be Part of Disciplined Learning**

## TATA INSTITUTE OF FUNDAMENTAL RESEARCH

## GS- 2024 ADMISSION TEST

Instructions for all candidates appearing for the Physics test for Ph.D. or Integrated Ph.D.**PLEASE READ THESE INSTRUCTIONS CAREFULLY BEFORE YOU ATTEMPT THE QUESTIONS**

- You may not keep with you any books, papers, mobile phones, or any electronic devices which can be used to get/store information. Use of **scientific, non-programmable calculators is permitted**. Calculators which plot graphs are not allowed. Multiple use devices, such as smart phone, etc. CANNOT be used as calculator.
- This test consists of TWO sections.
  - ❖ **SECTION A comprises 25 questions, numbered Q1 - Q25.** ----These are questions on basic topics.
  - ❖ **SECTION B comprises 15 questions, numbered Q1 - Q15.** ----These may require somewhat more thought/knowledge.
  - ❖ **SECTION C comprises 15 questions, numbered Q1 - Q15.** ----These may require somewhat more thought/knowledge.
- ALL questions are Multiple-Choice Type. In each case, ONLY ONE option is correct. Answer them by clicking the radio button next to the relevant option.
- If your calculated answer does not match any of the given options exactly, you may mark the closest one if it is reasonably close.
- The **grading scheme** will be as follows:
  - ❖ Section A : **+3** marks if correct; **-1** mark if incorrect; **0** marks if not attempted
  - ❖ Section B : **+5** marks if correct; **0** marks if incorrect or not attempted, i.e. NO negative marks.
  - ❖ Section C : **+5** marks if correct; **0** marks if incorrect or not attempted, i.e. NO negative marks.

**Section-A**

(For both Integrated M.Sc.--Ph.D. and Ph.D. candidates)

Q1. Which of the following sheets of paper can be turned into a regular octahedron (a three-dimensional regular polyhedron with eight triangular faces, as shown on the right) by folding along the marked lines?

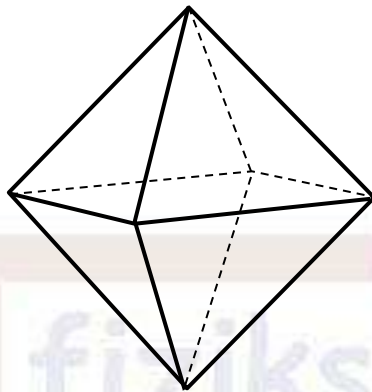

(a)

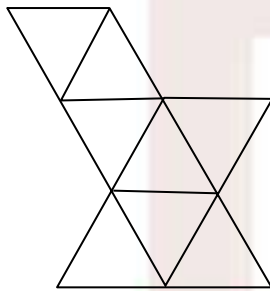

(b)

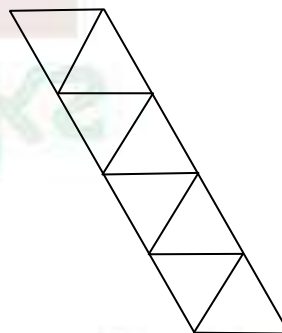

(c)

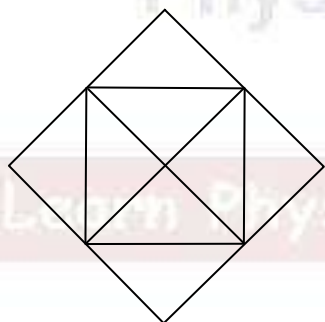

(d)

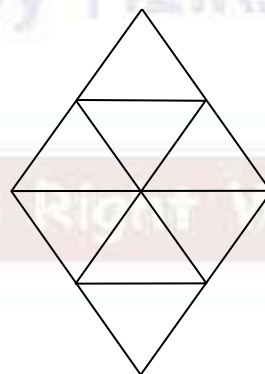

**Ans: (a)**

Q2. A surface is given by  $2x^3z + 4y^2z + 3z^2 = 81$ . Which of the following is a vector tangential to it at the point on the surface with coordinates  $(x, y, z) = (1, 2, 3)$ ?

(a)  $-3\hat{i} - 2\hat{j} + 6\hat{k}$

(b)  $18\hat{i} + 48\hat{j} + 36\hat{k}$

(c)  $-3\hat{i} + 2\hat{j} + 6\hat{k}$

(d)  $2\hat{i} - 3\hat{j} + 3\hat{k}$

**Ans: (d)**

Q3. Consider the following differential equations:

$$\frac{dx}{dt} = ay(t), \quad \frac{dy}{dt} = a$$

where  $a$  is a positive constant. The solutions to these equations define a family of curves in the  $x, y$  plane. What are these curves?

- (a) Circles                      (b) Parabolas                      (c) Hyperbolas                      (d) Ellipses

Ans: (b)

Q4. Consider a mass  $m$  connected to a network of massless springs shown in the figure below.

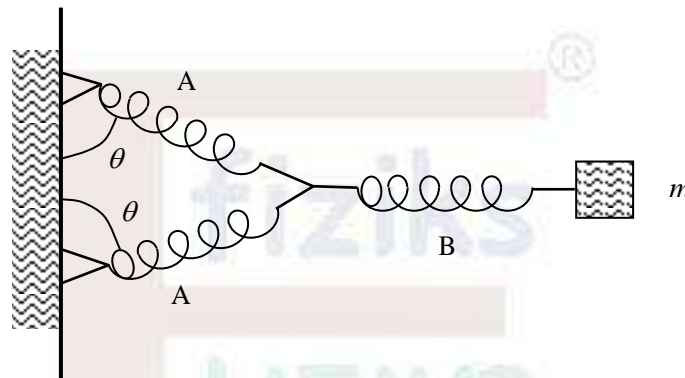

The spring constant of spring  $A$  is  $k_A$ , and that of spring  $B$  is  $k_B$ . The springs are shown in a relaxed position, and the angle  $\theta$  in this position is  $\pi/3$ . The mass is displaced horizontally by a small distance. What is the angular frequency of small oscillations of  $m$ ? (Ignore gravity and friction.)

- (a)  $\sqrt{2(k_A k_B) / [m(k_B + 2k_A)]}$                       (b)  $\sqrt{(k_A k_B) / [m(k_B + k_A)]}$   
 (c)  $\sqrt{(3k_A k_B) / [m(2k_B + 3k_A)]}$                       (d)  $\sqrt{(\sqrt{3}k_A k_B) / [m(k_B + \sqrt{3}k_A)]}$

Ans: (c)

Q5. Consider an object falling in air. In addition to gravity, it experiences an air resistance force,  $R$ , given by  $R = bv$ , where  $v$  is the speed and  $b$  is a constant. If the object is dropped from rest ( $v = 0$  at  $t = 0$ ), the distance traversed by the object at  $t = m/b$  is:

- (a)  $\left(\frac{m^2 g}{b^2}\right)\left(2 - \frac{1}{e}\right)$                       (b)  $\left(\frac{m^2 g}{b^2}\right)\left(1 - \frac{1}{e}\right)$   
 (c)  $\left(\frac{m^2 g}{b^2}\right)(e - 1)$                       (d)  $\left(\frac{m^2 g}{b^2}\right)\left(\frac{1}{e}\right)$

Ans: (d)

Q6. A frictionless disk of mass  $m$  is balanced at rest on the edges of two platforms at points  $A$  and  $B$  that are at equal height as shown below. The angle made by the line joining the centre to point  $A$  (line  $CA$ ) with the vertical is  $\pi/3$ .

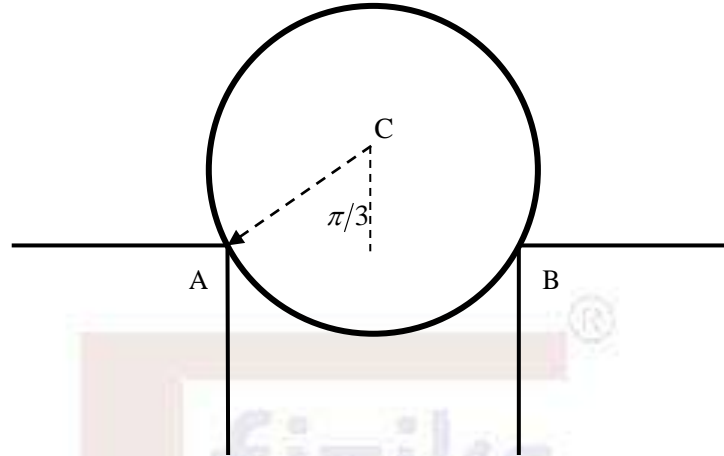

What is the magnitude of the force exerted by point  $A$  on the disk?

- (a)  $mg$                       (b)  $\frac{mg}{2}$                       (c)  $\frac{mg}{\sqrt{3}}$                       (d)  $\frac{mg\sqrt{3}}{2}$

Ans: (a)

Q7. Consider a particle of mass  $m$  moving in a one-dimensional potential of the form

$$V(x) = \begin{cases} \frac{1}{2}kx^2 & \text{for } x > 0 \\ \infty & \text{for } x \leq 0 \end{cases}$$

In a quantum mechanical treatment, what is the ground state energy of the particle?

- (a)  $\frac{1}{2}\hbar\sqrt{\frac{k}{m}}$                       (b)  $\frac{3}{2}\hbar\sqrt{\frac{k}{m}}$                       (c)  $\hbar\sqrt{\frac{k}{m}}$                       (d)  $\frac{5}{2}\hbar\sqrt{\frac{k}{m}}$

Ans: (b)

Q8. The un-normalized energy eigenfunction of a one-dimensional simple quantum harmonic oscillator in dimensionless units ( $m = \hbar = \omega = 1$ ) is

$$\psi_a(x) = (2x^3 - 3x)e^{-x^2/2}$$

Which of the following are two other (un-normalized) eigenfunctions which are closest in energy to  $\psi_a$ ?

- (a)  $(2x^2 - 1)e^{-x^2/2}; (4x^4 - 12x^2 + 3)e^{-x^2/2}$                       (b)  $e^{-x^2/2}; (2x^2 - 1)e^{-x^2/2}$   
 (c)  $xe^{-x^2/2}; (4x^5 - 20x^3 + 15x)e^{-x^2/2}$                       (d)  $(2x^2 - 1)e^{-x^2/2}; (4x^5 + 20x^3 + 15x)e^{-x^2/2}$

Ans: (a)

Q9. A quantum-mechanical state of a particle, with Cartesian coordinates  $x, y$  and  $z$ , is described by the normalized wave function

$$\psi(x, y, z) = \frac{\alpha^{5/2}}{\sqrt{\pi}} z e^{-\alpha\sqrt{x^2+y^2+z^2}}$$

For this state what are the angular quantum number  $\ell, L^2$  and  $L_z$  respectively?

- (a)  $1; 2\hbar^2; \hbar$                       (b)  $0; 0; 0$                       (c)  $1; 2\hbar^2; 0$                       (d)  $2; 6\hbar^2; 0$

Ans: (c)

Q10. A thin spherical shell of radius  $R$  has a constant surface charge density  $\sigma$ . This shell is cut symmetrically into two pieces. What is the electrostatic force between the two halves?

- (a)  $2\pi \frac{\sigma^2 R^2}{\epsilon_0}$                       (b)  $\frac{\pi \sigma^2 R^2}{4 \epsilon_0}$                       (c)  $\pi \frac{\sigma^2 R^2}{\epsilon_0}$                       (d)  $\frac{\pi \sigma^2 R^2}{2 \epsilon_0}$

Ans: (d)

Q11. Consider a system of three electric charges: (i) charge  $-q$  placed at the point  $(x, y, z) = (0, 0, d)$ , (ii) a charge  $+\alpha q$  placed at the origin and (iii) a charge  $-\beta q$  placed at the point  $(x, y, z) = (0, 0, -d)$ .

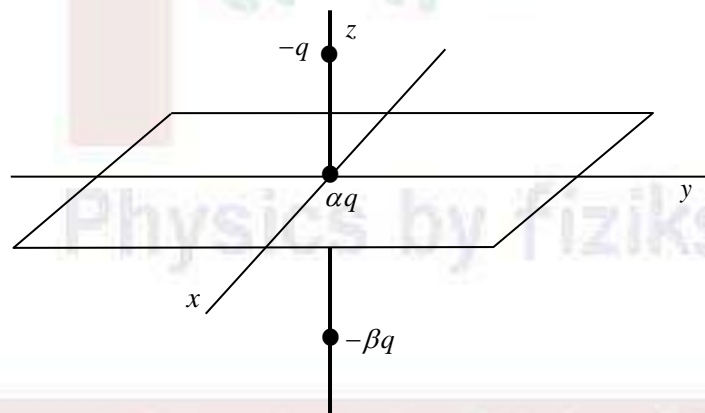

The value of  $\alpha$  and  $\beta$  are such that the monopole and dipole terms vanish in the multipole expansion of the electrostatic potential.

What is the quadrupole term of the potential at a point  $(x, y, 0)$ ?

- (a)  $\frac{q}{4\pi \epsilon_0} \frac{d^2}{(x^2 + y^2)^{3/2}}$                       (b)  $\frac{q}{2\pi \epsilon_0} \frac{d^2}{(x^2 + y^2)^{3/2}}$                       (c)  $0$                       (d)  $\frac{q}{4\pi \epsilon_0} \frac{1}{(x^2 + y^2)^{1/2}}$

Ans: (a)





Q15. An ideal gas on the Pressure ( $P$ )-Volume ( $V$ ) diagram can be taken from point  $K$  to point  $N$  along three different paths, as shown below.  $K \rightarrow L \rightarrow N$ ,  $K \rightarrow N$ , and  $K \rightarrow M \rightarrow N$ . Which of the following options is a true statement?

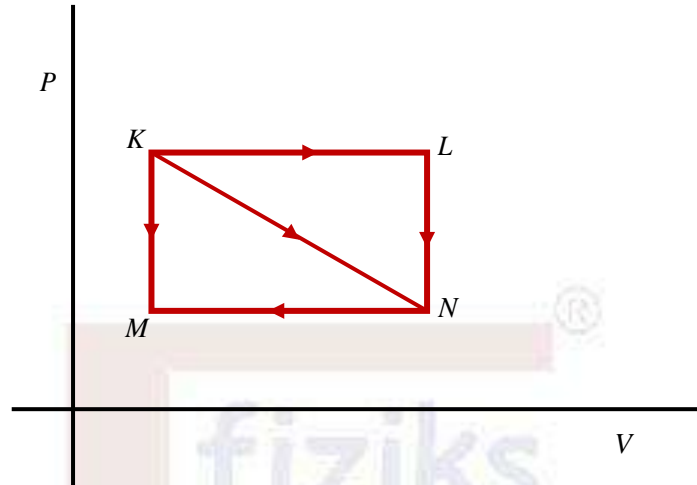

- (a) The change in internal energy is the same along each path
- (b) The same work is done along each path
- (c) The same amount of heat is added to each the gas along each path
- (d) There is no work done along the path  $K \rightarrow N$

Ans: (a)

Q16. A technician receives an electronic instrument on which the following circuit diagram is drawn. Based on the shown timing diagram (binary values at pins 1, 2, 3, 4, 5 as a function of time) measured by the technician, identify the fault in the instrument.

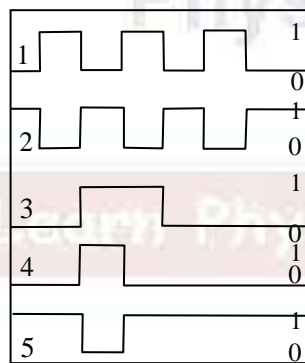

Timing diagram



Electronic circuit diagram

- (a) An AND gate is used where an OR gate should have been used
- (b) Input inverter acts like an OR gate
- (c) Pin 4 shorted to ground
- (d) Output inverter is faulty

Ans: (a)



Q17. The minimum number of two input NAND gates required to obtain the output  $Y = \bar{A}B + \bar{C}$  from three inputs A, B and C is:

- (a) 4 (b) 7 (c) 3 (d) 6

**Ans: (c)**

Q18. A student measures the radioactive decay of a material with a half-life of 13,000 years with a Geiger counter. In the laboratory notebook, the student records the following number of decays every 10 seconds:

158, 146, 145, 163, 154, 163, 160, 160, 152, 157, 154, 156, 149, 168, 152

The teacher suspects that the experiment was not done properly and the student created the numbers manually.

Why would the teacher have such a suspicion?

- (a) The variance is much less than the mean, unlike what is expected for a Poisson distribution.  
(b) The standard deviation is much less than the variance, as expected for a Poisson distribution.  
(c) The median is less than the mean, unlike what is expected for a Poisson distribution.  
(d) The median is greater than the mean, as expected for a Poisson distribution.

**Ans: (a)**

Q19. Unpolarised light of intensity  $200 \text{ W/m}^2$  is incident on a set of two perfect polarisers arranged one behind the other. The first polariser has its transmission axis at  $+55^\circ$  with respect to the vertical and the second polariser has its transmission axis at  $+100^\circ$  with respect to the vertical. What is the intensity of the transmitted light?

- (a)  $100 \text{ W/m}^2$  (b)  $50 \text{ W/m}^2$  (c)  $1.98 \text{ W/m}^2$  (d)  $3.01 \text{ W/m}^2$

**Ans: (b)**

Q20. Two small loudspeakers A and B, separated by 15 cm, were pointed toward a small microphone M at a distance 1.5 m away from the centre of the line AB, in the perpendicular direction as shown in the sketch below.



The following sound intensity pattern was observed as a function of the position of the microphone as it is moved parallel to AB.

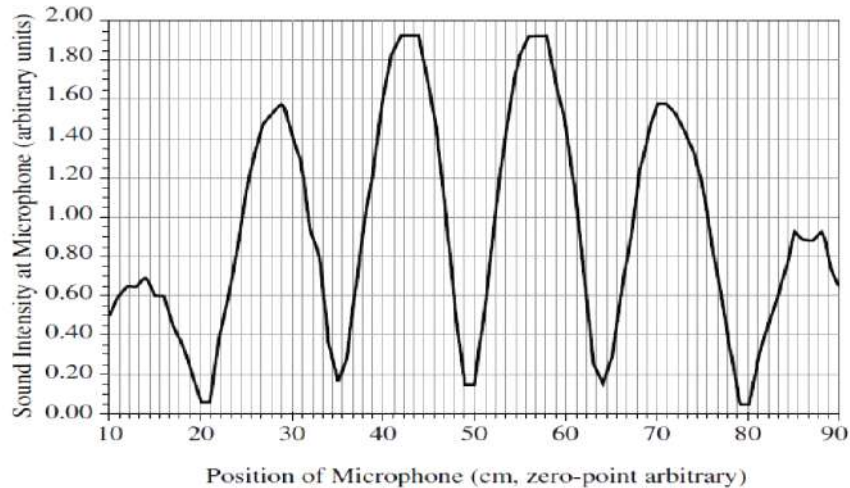

The dips in the signal were repeated at the interval of 14.5 cm. The speed of sound in the experiment's background condition is 343 m/s. What can we conclude from this information?

- (a) The two loudspeakers are vibrating at frequency 23.65 kHz and they are out of phase.
- (b) The two loudspeakers are vibrating at frequency 23.65 kHz and they are in phase.
- (c) The two loudspeakers are vibrating at frequency 47.3 kHz and they are in phase.
- (d) The two loudspeakers are vibrating at frequency 47.3 kHz and they are out of phase.

**Ans: (a)**

Q21. The ionization potential of the H atom is 13.598 eV. If the mass of a proton is  $1.673 \times 10^{-27}$  kg, the mass of an electron is  $9.109 \times 10^{-31}$  kg and the mass of the D nucleus is  $3.344 \times 10^{-27}$  kg, the ionization potential of the D atom is given by:

- (a) 13.598 eV
- (b) 13.594 eV
- (c) 13.602 eV
- (d) 27.188 eV

**Ans: (c)**

Q22. Consider a spaceship  $S$  of length  $L$  is moving relativistically in the  $x$  direction with a speed  $v_x$  relative to an inertial reference frame  $F$  as shown in the figure. In  $S$ , a light bulb is placed at the left end (point  $A$ ) and a detector is placed at the right end (point  $B$ ). What is the time taken for light to travel from  $A$  to  $B$  in the reference frame  $F$  ?

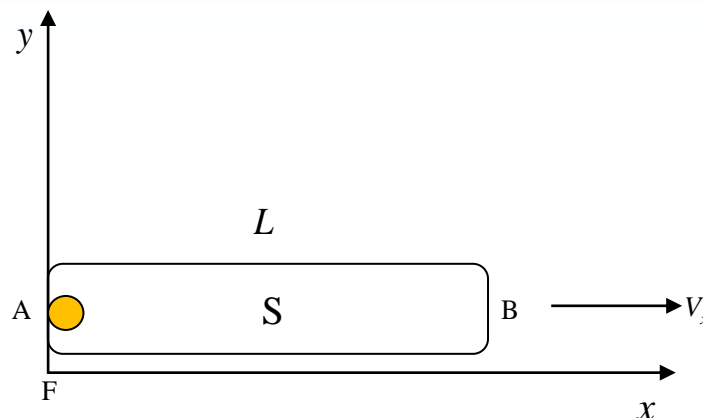

(a)  $\frac{L}{c} \sqrt{\frac{1+v_x/c}{1-v_x/c}}$

(b)  $\frac{L}{c} \sqrt{1-\frac{v_x^2}{c^2}}$

(c)  $\frac{L}{c} \sqrt{\frac{1-v_x/c}{1+v_x/c}}$

(d)  $\frac{L}{c} \frac{1}{\sqrt{1-v_x^2/c^2}}$

**Ans: (a)**

Q23. A beam of neutrons is incident normally upon a thick sheet of Cadmium. The mass density of Cadmium is  $\rho = 8.6 \text{ g cm}^{-3}$ . The absorption cross-section of neutrons on Cadmium nuclei is  $2.5 \times 10^{-20} \text{ cm}^2$ . The atomic weight of Cadmium is known to be 112.40 g/mol. You may take  $N_A = 6.02 \times 10^{23}$ . At what depth is the intensity of the beam reduced by a factor  $1/e$ ?

(a)  $9 \mu\text{m}$ 

(b) 9 fm

(c) 9 nm

(d) 900 fm

**Ans: (a)**

Q24. An electron confined in a two-dimensional square box, is in the ground state. The length of the side of this square is unknown, but it is seen that the electron jumps to the first excited energy state by absorbing electromagnetic radiation of wavelength 4,040 nm. What is the length of one side of the square well?

(a) 3.82 nm

(b) 1.68 nm

(c) 2.55 nm

(d) 1.91 nm

**Ans: (d)**

Q25. A student designed a new semiconductor with lattice constant  $a$  that crystallizes in the face-centered cubic (fcc) structure. The conduction band minimum of this semiconductor lies at all momentum points equivalent to  $\vec{k} = (0.5, 0, 0)\pi/a$ . How many conduction band minimum points are inside the first Brillouin zone?

(a) 6

(b) 4

(c) 3

(d) 1

**Ans: (a)**

Learn Physics in Right Way

**Section B**

(only for Integrated M.Sc.-Ph.D. candidates)

Q1. The following series  $S = \sum_{n=1}^{\infty} (-1)^{1+n} \frac{1}{n2^{4n}}$  has the sum

(a)  $S = \sqrt{\frac{17}{16}}$

(b)  $S = \ln\left(\frac{17}{16}\right)$

(c)  $S$  is not convergent

(d)  $S = \frac{1}{1 + \sqrt{\frac{1}{16}}}$

**Ans: (b)**

Q2. Consider a particle of mass  $m$  orbiting around a central potential  $V(r) = -\frac{a}{r} - \frac{b}{r^3}$  with  $a, b > 0$ . What is the smallest angular momentum it must have to be in a stable orbit?

(a)  $(3abm^2)^{1/4}$

(b)  $(4abm^2)^{1/4}$

(c)  $(12abm^2)^{1/4}$

(d)  $(6abm^2)^{1/4}$

**Ans: (c)**

Q3. Two equal masses  $m$  are connected with a massless string. The first mass is initially set in a uniform circular motion with speed  $v_i$  at a radius  $r_i$  on top of a table while the second mass hangs vertically on the string which passes through a hole in the centre of the table (C), as shown in the figure below.

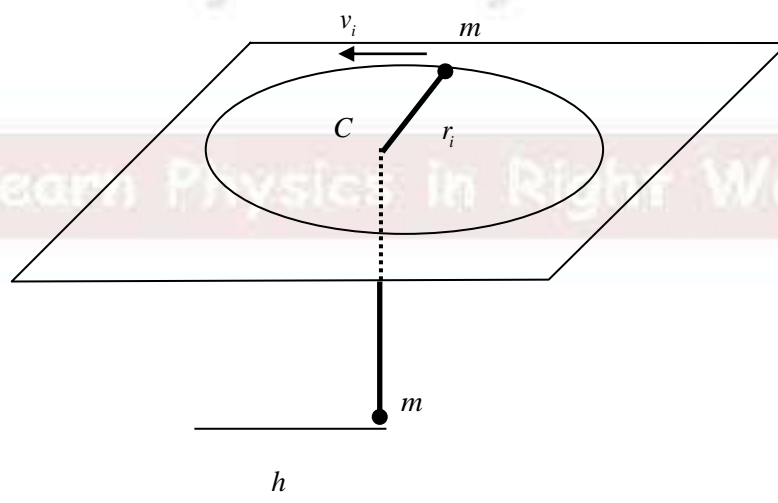

The system is released with this initial configuration and the second mass starts falling. What is the net speed of the first mass when the second mass has fallen a height  $h$  (smaller than  $r_i$ )?

(Assume that there is no friction and that the string always remains tight.)

(a)  $\sqrt{gh + \frac{1}{2}v_i^2 \left[ 1 + \frac{r_i^2}{(r_i - h)^2} \right]}$

(b)  $\sqrt{gh + \frac{1}{2}v_i^2 \left[ 1 + \frac{r_i}{(r_i - h)^2} \right]}$

(c)  $\sqrt{gh + \frac{1}{2}v_i^2 \left[ 1 + \frac{(r_i - h)^2}{r_i^2} \right]}$

(d)  $\sqrt{gh + \frac{1}{2}v_i^2 \left[ 1 + \frac{(r_i - h)}{r_i} \right]}$

Ans: (a)

Q4. Consider a particle of mass  $m$  moving in an infinite one-dimensional potential well of length  $L$  between points  $A$  and  $B$ . In a quantum-mechanical treatment, the particle is in the ground state with an energy  $E_g$ . The wall at  $B$  is suddenly shifted to  $B'$  where  $AB'$  has length  $2L$ . If we measure the energy again, what is the most probable result?

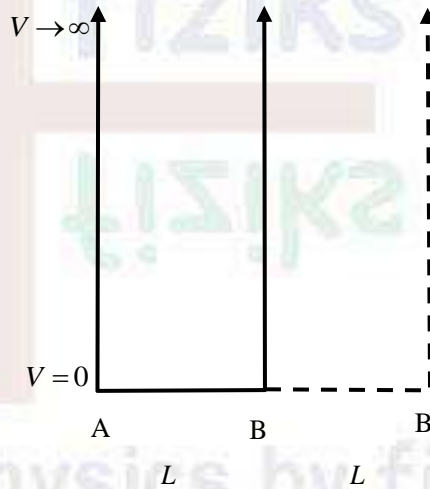

(a)  $E_g/4$

(b)  $E_g$

(c)  $4E_g$

(d)  $9E_g/4$

Ans: (b)

Q5. A particle of mass  $m$  is subjected to a force  $\vec{F}(\vec{r})$  such that the wavefunction  $\phi(\vec{p}, t)$  satisfies the momentum-space Schrodinger equation

$$\left( \frac{\vec{p}^2}{2m} - a\vec{\nabla}_p^2 \right) \phi(\vec{p}, t) = i\hbar \frac{\partial}{\partial t} \phi(\vec{p}, t)$$

where  $a$  is a real constant and  $\vec{\nabla}_p^2 = \frac{\partial^2}{\partial p_x^2} + \frac{\partial^2}{\partial p_y^2} + \frac{\partial^2}{\partial p_z^2}$ . It follows that  $\vec{F}(\vec{r}) =$

(a)  $-\frac{2a}{\hbar^2} \vec{r}$

(b)  $\frac{2a}{\hbar^2} \vec{r}$

(c)  $-a\hbar^2 \frac{\vec{r}}{r^3}$

(d)  $a\hbar^2 \frac{\vec{r}}{r^3}$

Ans: (a)

- Q6. A conducting square loop of wire (side  $a$ ) lies on a table, at a distance  $s$  from an infinite straight wire as shown in the figure. The infinite wire carries a current  $I$  in the  $x$  direction as shown. If one now pulls the loop directly away from the wire in the  $y$  direction at a constant speed  $v$ , what is the generated EMF in the loop? In what direction (clockwise or counterclockwise) does the current flow in the loop?

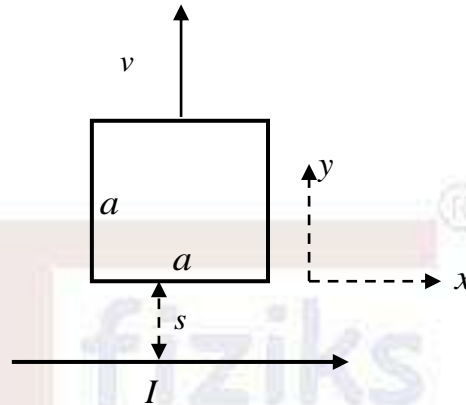

- (a)  $\frac{a^2 v I \mu_0}{2\pi (as + s^2)}$ , anticlockwise      (b)  $\frac{a^2 v I \mu_0}{2\pi (as + s^2)}$ , clockwise  
 (c)  $\frac{av I \mu_0}{2\pi (a + s)}$ , anticlockwise      (d)  $\frac{av I \mu_0}{2\pi (a + s)}$  clockwise

Ans: (a)

- Q7. Consider an electric dipole of strength  $p$  placed near a grounded infinite conducting sheet in the  $xy$  plane at a distance  $d$  from it in the  $z$  direction as shown below. The centre of the dipole (C) is fixed to a pivot but the dipole is free to rotate about the  $x$  axis (coming out of the page).

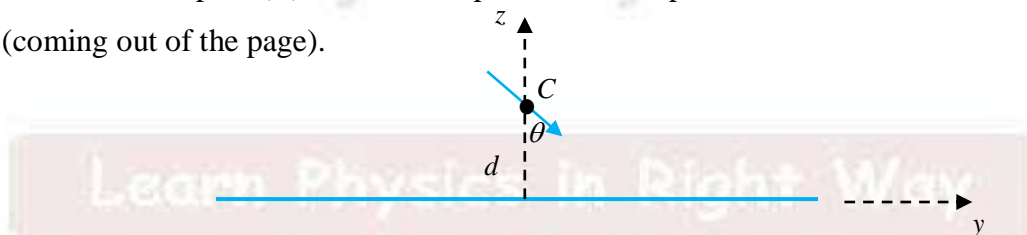

What is the magnitude of the torque on the dipole when the angle between the dipole and the positive  $z$  axis is  $(\pi - \theta)$  as shown?

- (a)  $\tau = \frac{p^2}{(16\pi \epsilon_0 d^3)} \sin(\theta)$       (b)  $\tau = \frac{p^2}{(16\pi \epsilon_0 d^3)} \cos(2\theta)$   
 (c)  $\tau = \frac{p^2}{(64\pi \epsilon_0 d^3)} \cos(\theta)$       (d)  $\tau = \frac{p^2}{(64\pi \epsilon_0 d^3)} \sin(2\theta)$

Ans: (d)

Q8. A collection of  $N$  spin- $\frac{1}{2}$  objects, with individual energy eigenvalues  $0, E$  are kept at a temperature  $T$ . Which of the following curves accurately represent the temperature dependence of specific heat of the system?

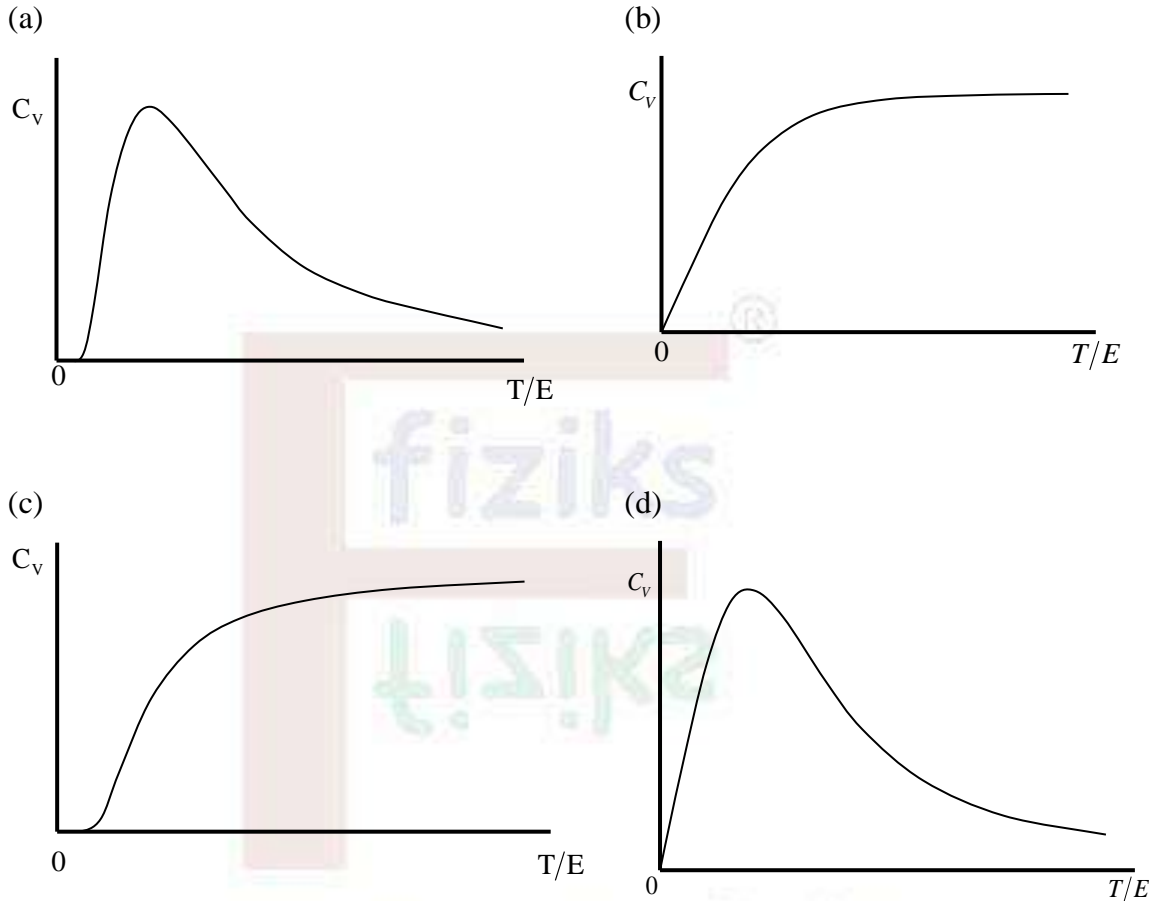

Ans: (a)

Q9. An ideal heat pump delivers heat at a rate  $\beta(T_H - T_S)$  from the colder surroundings ( $S$ ) at a temperature  $T_S$  to a heater ( $H$ ) kept at a constant temperature  $T_H$ . Here  $\beta$  is a constant. What is the power consumption of the heat pump?

- (a)  $\beta(T_H - T_S)$                       (b)  $\frac{\beta(T_H - T_S)^2}{T_H}$
- (c)  $\frac{\beta(T_H - T_S)^2}{T_S}$                       (d)  $\frac{\beta(T_H - T_S)T_H}{T_S}$

Ans: (b)



Q10. In the following ideal Op-Amp circuit

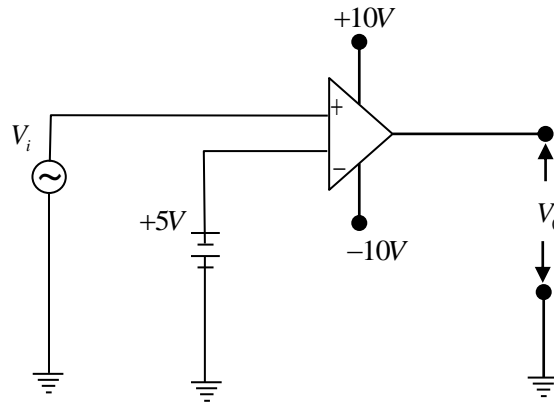

if the input voltage  $V_i$  is

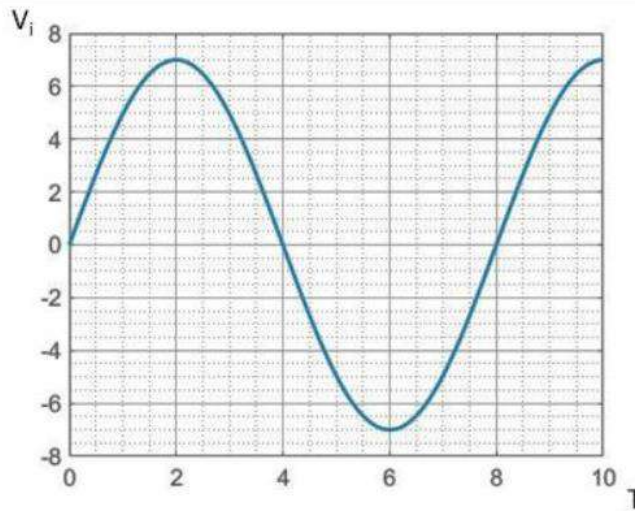

The output waveform would be

(a)

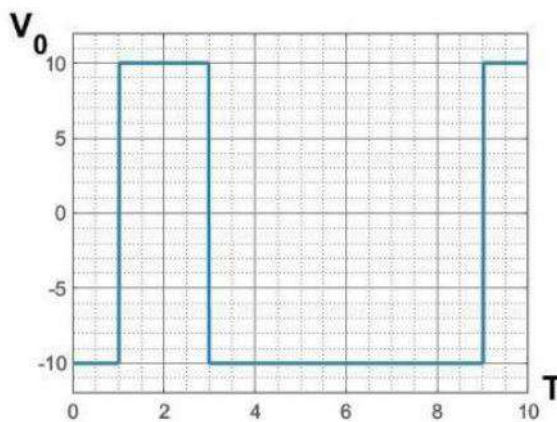

(b)

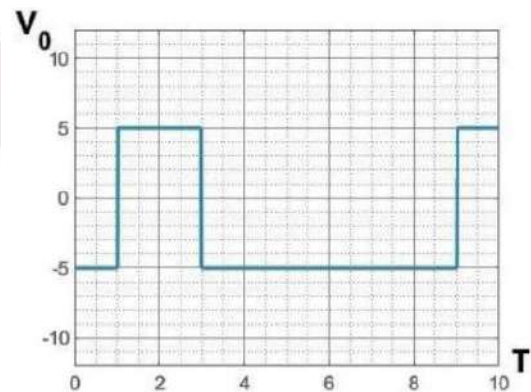

(c)

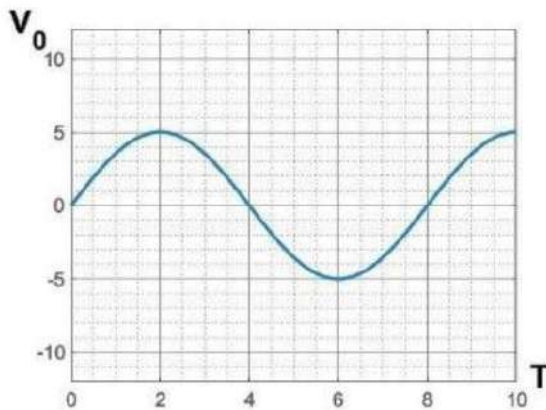

(d)

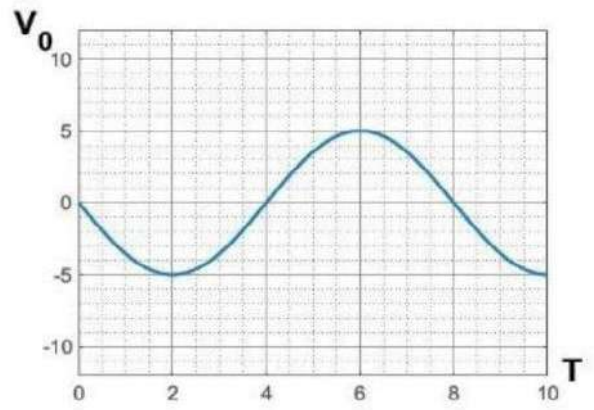

Ans: (a)

Q11. A mass spectrometer consists of a parallel plate capacitor with plates A and B that accelerates ions through an electric potential  $V$ , which is followed by a box carrying a uniform magnetic field  $B$  of magnitude 0.2 Tesla (coming out of the page as shown).

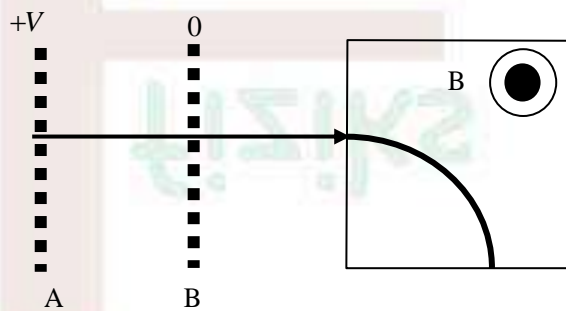

This setup is used to separate two isotopes of Uranium:

$$^{235}\text{U} \text{ (mass} = 3.93 \times 10^{-25} \text{ kg)}$$

$$^{238}\text{U} \text{ (mass} = 3.98 \times 10^{-25} \text{ kg)}$$

Singly charged ions (charge  $+e$ ) of the two isotopes are created at the plate A and pass without energy loss through plate B into the box. In order to separate the isotopes, their radii of curvature in the box must differ by 2 mm. What is the approximate  $V$  through which the ions must be accelerated in order to achieve this?

- (a) 8 Volts
- (b) 8000 Volts
- (c) 80 Volts
- (d) 800 Volts

Ans: (d)

- Q12. A tidal force is exerted on the oceans by the Moon. This can be estimated by the differential acceleration ( $\Delta g$ ) which is the difference between the gravitational acceleration at B and C due to the moon (see figure below).

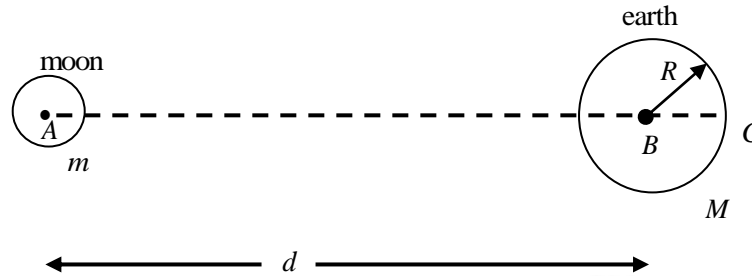

If  $R$  and  $M$  are the radius and mass of Earth,  $d$  the distance of separation of the centre of Earth and the moon, and  $m$  the mass of moon, which of the following answers is closest to the magnitude of  $\Delta g$  ?

- (a)  $\frac{2GmR}{d^3}$       (b)  $\frac{4GmR}{d^3}$       (c)  $\frac{GmR}{2d^3}$       (d)  $\frac{GmR^2}{d^4}$

Ans: (a)

- Q13. Incident unpolarized light is reflected from a glass ( $n_g = 1.65$ ) plate immersed in ethyl alcohol ( $n_a = 1.36$ ) and this reflection is found to be completely linearly polarised. Find the angle at which the incident light would be transmitted through the plate.

- (a)  $31.6^\circ$       (b)  $39.5^\circ$       (c)  $50.5^\circ$       (d)  $69.3^\circ$

Ans: (b)

- Q14. A massive particle moving at a speed of  $4c/5$  collides with an identical particle at rest. What would be the speed of the second particle in the center-of-mass frame after the collision?

- (a)  $c/2$       (b)  $2c/5$       (c)  $c/\sqrt{2}$       (d)  $2\sqrt{2}c/5$

Ans: (a)

- Q15. The energy dispersion in the conduction band of a one-dimensional metal with lattice spacing  $a$  is given by,

$$E(k) = E_0(1 - \cos ka)$$

where  $k \in (-\pi/a, +\pi/a]$ . Suppose that each site contributes one conduction electron to the conduction band. What is the Fermi energy of the system?

- (a)  $\frac{E_0}{4}$       (b)  $\frac{E_0}{2}$       (c)  $2E_0$       (d)  $E_0$

Ans: (d)

**Section C**

(only for Ph.D. candidates)

Q1. Consider the following matrix  $\mathbf{M} = \begin{pmatrix} 1 & 5 & -7 & 1 \\ 1 & 0 & 2 & 2 \\ 9 & -1 & 3 & 1 \\ 9 & 6 & -7 & -4 \end{pmatrix}$

What is  $\det e^{\mathbf{M}}$ ?

- (a) 1                                      (b)  $e$                                       (c)  $e^{1210}$                                       (d)  $e^{-1210}$

**Ans: (a)**

Q2. Let  $F(\lambda) = \int_{-\infty}^{+\infty} dx e^{\lambda x - x^2}$ .

If the Taylor series expansion of  $F(\lambda)$  around  $\lambda = 0$  is

$$F(\lambda) = F_0 + F_1\lambda + F_2\lambda^2 + \dots$$

then the value of  $F_2$  is

(You might find the following integral useful:  $\int_{-\infty}^{+\infty} dx e^{-\alpha x^2} = \sqrt{\frac{\pi}{\alpha}}$  for  $\alpha > 0$ )

- (a)  $\sqrt{\pi}/8$                                       (b)  $\sqrt{\pi}/4$                                       (c)  $\sqrt{\pi}/2$                                       (d)  $\sqrt{\pi}$

**Ans: (b)**

Q3. A horizontal constant force  $F$  is applied on a uniform disc placed on a horizontal surface. The mass of the disc is  $m$ , and the radius is  $r$ . The point of application of  $F$  is at a height  $h (< 2r)$  from the surface. The disc starts from rest at  $t = 0$  and rolls without slipping. What is the speed of the centre of the disc at time  $t$ ?

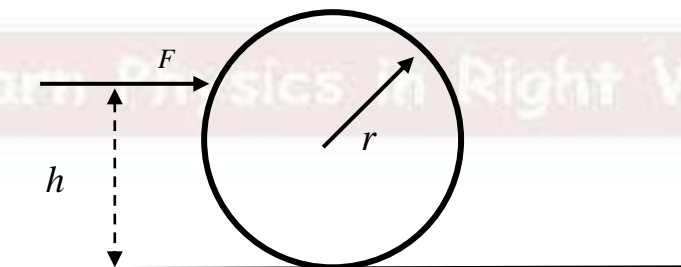

- (a)  $\frac{2Ft}{3m}$                                       (b)  $\frac{Ft}{m}$                                       (c)  $\frac{2Fht}{3mr}$                                       (d)  $\frac{3Fht}{2mr}$

**Ans: (c)**

Q4. A particle of mass  $m$  is attached to a massless string of length  $L$ . The other end of the string is fixed at a point  $P$  as shown in the figure.  $m$  moves under gravity and the tension of the string. The motion of the string is described using the generalized coordinates  $\theta$  and  $\phi$  which change with time.  $\theta$  is the polar angle made by the string with the vertical and  $\phi$  is the azimuthal angle made by the projection of the string on the  $xy$  plane. The conjugate momenta to the variables  $(\theta, \phi)$  are  $(p_\theta, p_\phi)$ , respectively.

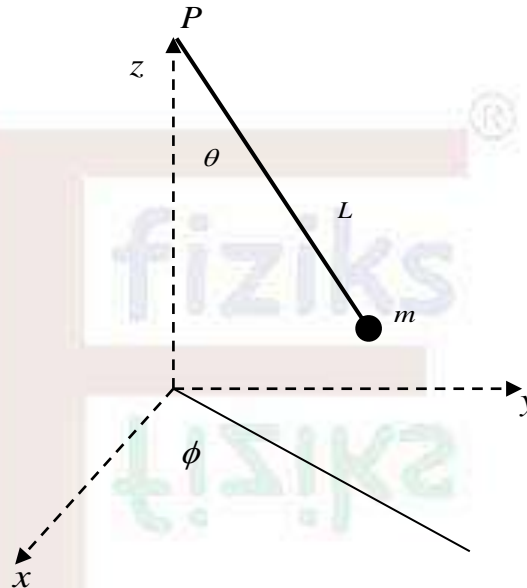

Assuming that the string is tight throughout the motion, the Hamiltonian for the system is given by:

- (a)  $\frac{1}{2m} [p_\theta^2 + p_\phi^2 \operatorname{cosec}^2 \theta] + 2mgL \sin^2 \left( \frac{\theta}{2} \right)$       (b)  $\frac{1}{2m} [p_\theta^2 + p_\phi^2 \operatorname{cosec}^2 \theta] - 2mgL \sin^2 \left( \frac{\theta}{2} \right)$   
 (c)  $\frac{1}{2m} [p_\theta^2 + p_\phi^2 \sin^2 \theta] + 2mgL \sin^2 \left( \frac{\theta}{2} \right)$       (d)  $\frac{1}{2m} [p_\theta^2 + p_\phi^2 \sin^2 \theta] - 2mgL \sin^2 \left( \frac{\theta}{2} \right)$

Ans: (a)

Q5. Consider  $\hat{x}$  and  $\hat{p}_x$  as the quantum mechanical position and linear momentum operators with eigenstates  $|x\rangle$  and  $|p_x\rangle$  and eigenvalues  $x$  and  $p_x$ , respectively.

The eigenvalue of  $\hat{x}$  acting on the state  $|\psi\rangle = e^{i\hat{p}_x a / 2\hbar} |x\rangle$  is

- (a)  $x - \frac{a}{2}$       (b)  $x + \frac{a}{2}$       (c)  $x + a$       (d)  $x - a$

Ans: (b)

Q6. A particle of mass  $m$  moving in 1 dimension has the wavefunction

$$\psi(x) = \frac{1}{\pi^{1/4} \sqrt{a}} e^{ipx/\hbar} e^{-x^2/2a^2}$$

Its average kinetic energy is given by

(You might find the following integral useful:  $\int_{-\infty}^{+\infty} dx e^{-\alpha x^2} = \sqrt{\frac{\pi}{\alpha}}$  for  $\alpha > 0$ )

- (a)  $\frac{p^2}{2m} + \frac{\hbar^2}{4a^2m} + \frac{p\hbar}{2ma}$       (b)  $\frac{\left(p + \frac{\sqrt{\pi}\hbar}{a}\right)^2}{2m}$
- (c)  $\frac{\left(-p + \frac{\sqrt{\pi}\hbar}{a}\right)^2}{2m}$       (d)  $\frac{p^2}{2m} + \frac{\hbar^2}{4a^2m}$

Ans: (d)

Q7. A smartphone emits electromagnetic radiation with a power of 1 Watt. What is the approximate value of the r.m.s. magnetic field at a distance 25 cm from the phone?

- (a)  $10^{-7}$  Tesla      (b)  $10^{-5}$  Tesla      (c)  $10^{-9}$  Tesla      (d)  $10^{-11}$  Tesla

Ans: (a)

Q8. Each site of a linear chain of  $N$  sites has a spin which can be in three different states with energies  $0, \pm \epsilon$ , as shown in the figure below.

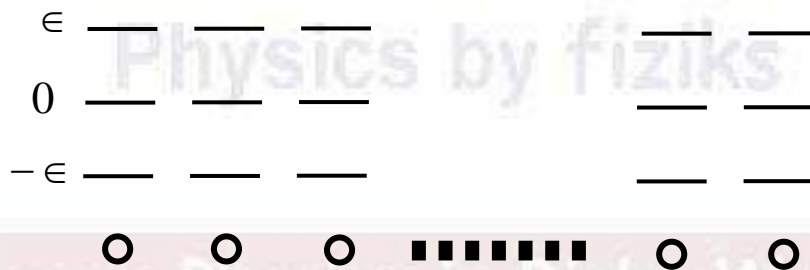

The system has a constraint that the neighbouring spins cannot be in the same state. At infinite temperature, the entropy of the system is given by:

- (a)  $N \ln 3$       (b)  $N \ln 2 + \ln \frac{3}{2}$       (c)  $(N-1) \ln 2$       (d)  $N \ln 2$

Ans: (b)



Q9. Consider a charge particle detection chamber as shown in the figure below. The chamber is made of a set of parallel plates separated by 20 mm distance and connected to the external resistance ( $R = 100\Omega$ ) as shown in the figure along with the high voltage power supply of 1 kV.

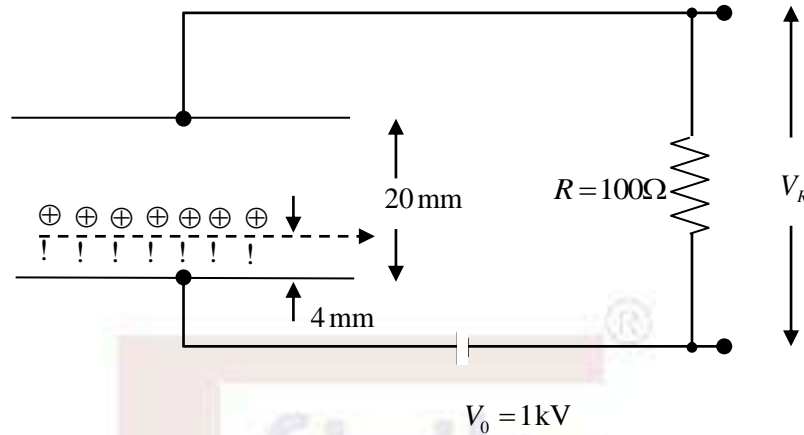

The chamber is filled with Argon (Ar) gas (ionization energy 16 eV). If a charged particle passes through the chamber and loses sufficient energy, it ionizes the Ar atoms and generates a small voltage pulse across the resistance R.

In an experiment, an alpha particle of energy 5.5 MeV enters the chamber at a distance of 4 mm from the bottom plate, as shown, generating ion-electron pairs. If the effective capacitance of the chamber is 100 pF, the measured voltage pulse shape would be best described as:

- (a) A sharp voltage pulse followed by a very weak broad pulse
- (b) Two sharp voltage pulses of equal magnitude and opposite signs
- (c) Two sharp voltage pulses of the same magnitude and sign
- (d) No voltage pulse would be generated as both electrons and ions will neutralise the charge collected by the capacitor

**Ans: (a)**

Q10. A particular counting system has an average background rate of 50 counts/min. A decaying radioisotope source was introduced and the total 168 counts were measured in one minute. After a delay of 24 hrs, the system measured total 91 counts in one minute. If these measurements were used for determining the half-life ( $\tau$ ) of the source and if the average background rate, and the time have no errors, the % error ( $100 \times \sigma_\tau / \tau$ ) in the calculated half-life value due to counting statistics would be:

- (a) 24.3 %
- (b) 21.2 %
- (c) 25.7 %
- (d) 18.2 %

**Ans: (a)**



Q11. The Hamiltonian for a Helium atom is given as  $H = H_0 + H_1$ , where

$$H_0 = \frac{(p_1^2 + p_2^2)}{2\mu} - \frac{2e^2}{4\pi\epsilon_0 r_1} - \frac{2e^2}{4\pi\epsilon_0 r_2}$$

and

$$H_1 = \frac{e^2}{4\pi\epsilon_0 r_{12}}$$

where  $\mu$  is the reduced mass of the electron,  $r_1$  and  $r_2$  are the distance of the electrons from the nucleus, and  $r_{12}$  is the distance between the two electrons. The value of the first ionization potential of the Helium atom is 24.6 eV.

What is the correction due to  $H_1$  to the ground state energy of the Helium atom, compared to  $H_0$ ?

- (a) 84.2 eV                      (b) -29.8 eV                      (c) 29.8 eV                      (d) -2.6 eV

**Ans: (c)**

Q12. Oxygen (O) nuclei ( $Z = 8$ ) can be approximated as non-interacting protons and neutrons filling up orbitals in the following order.

$$1s_{1/2}, 1p_{3/2}, 1p_{1/2}, 1d_{5/2}, 2s_{1/2}, 1d_{3/2}, \dots$$

where the subscript specifies the  $J$  quantum number. Given the binding energy of O ( $A = 15$ ) is 111.96 MeV, O ( $A = 16$ ) is 127.62 MeV, and O ( $A = 17$ ) is 131.76 MeV, what is the difference between the energies of the  $1p_{1/2}$  and the  $1d_{5/2}$  orbitals?

- (a) 15.66 MeV                      (b) 11.52 MeV                      (c) 4.14 MeV                      (d) 19.81 MeV

**Ans: (b)**

Q13. Consider a universe that always expands with a scale factor  $a$  that increases with time as  $a(t) = Ct^{2/3}$  where  $C$  is a constant. Its expansion rate at time  $t$  is defined by the Hubble

parameter

$$H(t) = \frac{1}{a(t)} \frac{da(t)}{dt}$$

The current value of  $H(t)$  in the universe is given by  $H_0 = 975 \text{ km s}^{-1} \text{ Mpc}^{-1}$  where  $1 \text{ Mpc} = 3.1 \times 10^{22} \text{ m}$ . What is the approximate age of this universe?

- (a)  $10^9$  years                      (b)  $10^7$  years                      (c)  $10^{11}$  years                      (d)  $10^{13}$  years

**Ans: (a)**

Q14. An X-ray of wavelength  $3.1\text{\AA}$  incident on the (110) plane of a cubic lattice with lattice constant  $a$  produces a second-order Bragg reflection at  $\theta = 30^\circ$  ( $\theta$  is the angle measured from normal to the plane as shown in the figure).

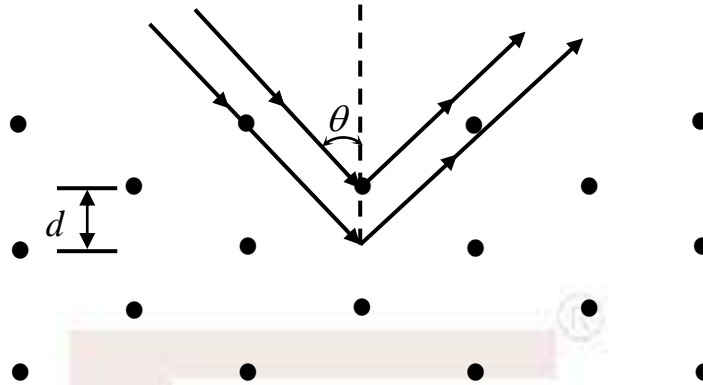

What is the value of  $a$ ?

- (a)  $5.46\text{\AA}$                       (b)  $8.77\text{\AA}$                       (c)  $3.58\text{\AA}$                       (d)  $5.06\text{\AA}$

Ans: (d)

Q15. Consider an unstable bound state  $B$  of a proton ( $p$ ) with an antiproton ( $\bar{p}$ ), which is in the S-state ( $\ell = 0$ ) in the spin-singlet configuration. When this state  $B$  decays, which of the following final states will NOT be possible?

- (a)  $\gamma + \gamma + \gamma$                       (b)  $\mu^+ + \mu^- + \gamma$                       (c)  $\gamma + \gamma$                       (d)  $e^+ + e^- + \gamma$

Ans: (a)

Learn Physics in Right Way

## Learn Physics in Right Way

### Courses for NET-JRF, IIT-JAM, GATE, JEST, TIFR & Other M.Sc. Entrances



*Offline Classes*



*Online Live Classes*



*Online Pre-recorded Classes*

*Study Material*

*Online Test Series*

*Interview Guidance*

## Our Teaching Methodologies

- Well Planned Course Structure
- Develop Conceptual Clarity
- Learn Problem Solving Techniques
- Build Speed and Accuracy
- Individual Mentoring
- One on One Discussion
- Instant Doubts Clearing
- Steps to Achieve Competence [QIP]
- Better Time Management
- Performance Analysis
- Student Learning Outcome

### Be Part of Disciplined Learning



**011-26865455, +9871145498**

Head Office: House No. 40-D, Ground Floor, Jia Sarai  
Near IIT-Delhi, Hauz Khas, New Delhi-110016

## Achivements : Year [2022-23]

Total Selections

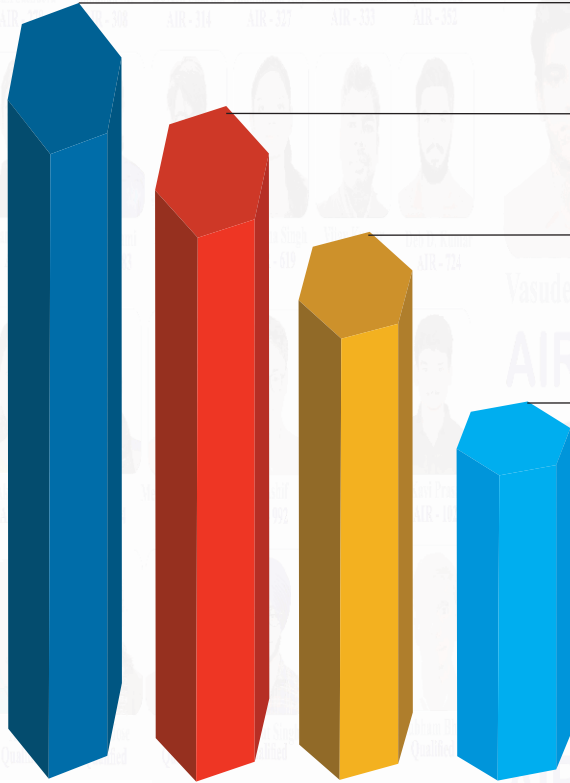

NET-JRF [2022] #97



Kulwinder Kumar  
**AIR - 01**

IIT-JAM [2023] #90



Hitesh Pandey  
**AIR - 03**

GATE [2023] #83



Pritam Manna  
**AIR - 03**

JEST [2023] #42



Sunish Prashar  
**AIR - 04**

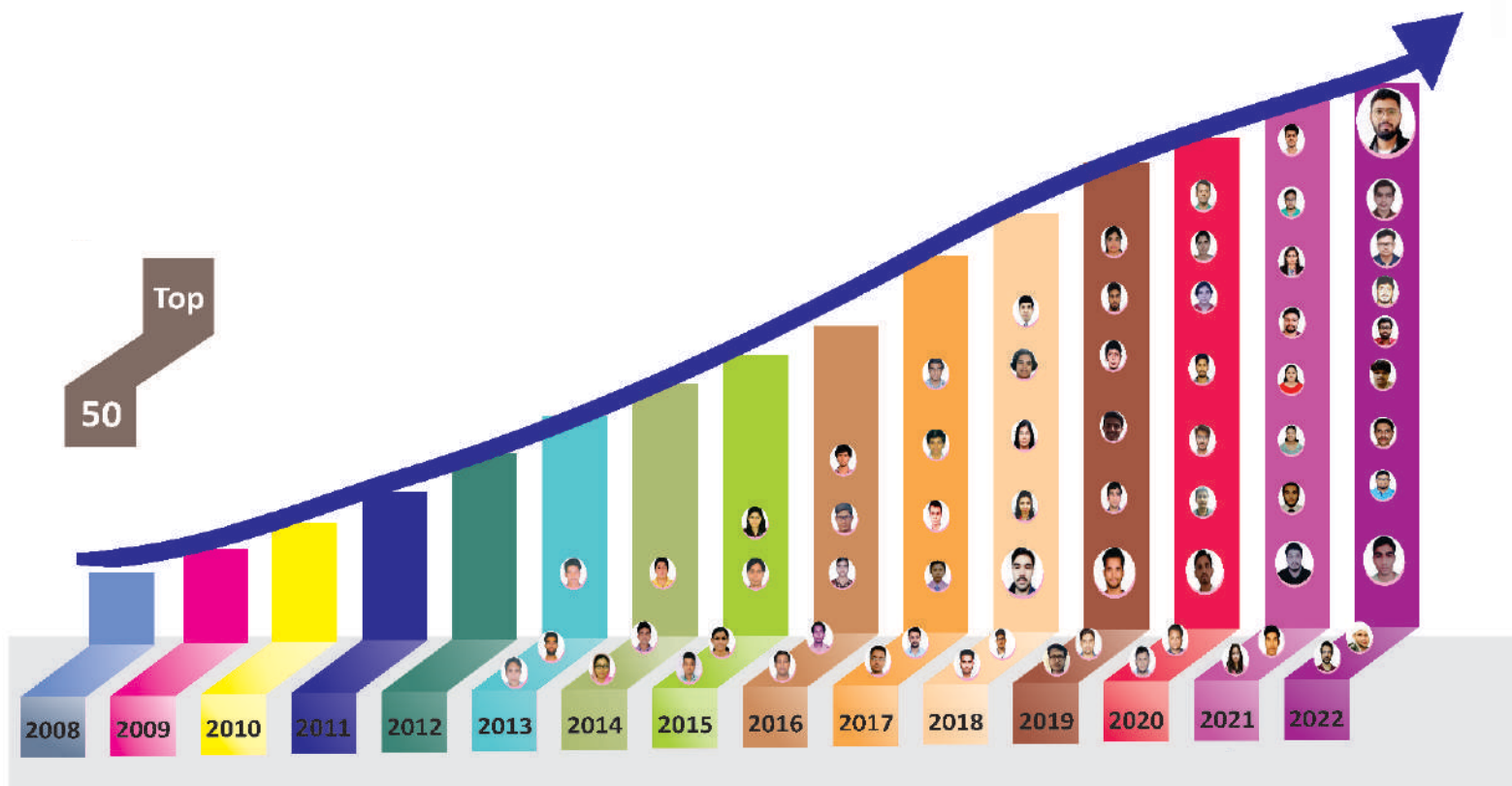

Top

50